



SPECIALTY GAS MANIFOLD SYSTEMS *International Edition*

Specialty Gas Control Panels • Terminal Gas Control Panels • Other Control Systems • Manifolds

Technology for a Better Future

TABLE OF CONTENTS

GENTEC® Specialty Gas Products

Specialty Gas Equipment

01. **Company Overview**
02. **Panel Overview**
03. **Lab Design**



05.-12. Chrome-plated Brass Specialty Gas Control Panels

05. P3200B series Single-Bank Specialty Gas Control Panels
07. P3300B series Dual-Bank Specialty Gas Control Panels
09. P3400B series Semi-Automatic Specialty Gas Control Panels
11. P3500B series Semi-Automatic In-Line Repair Specialty Gas Control Panels



13.-28. Stainless Steel Specialty Gas Control Panels

13. P3200S series Single-Bank High Pressure Specialty Gas Control Panels
15. P3200S series Single-Bank Low Pressure Specialty Gas Control Panels
17. P3300S series Dual-Bank High Pressure Specialty Gas Control Panels
19. P3300S series Dual-Bank Low Pressure Specialty Gas Control Panels
21. P3400S series Semi-Automatic High Pressure Specialty Gas Control Panels
23. P3400S series Semi-Automatic Low Pressure Specialty Gas Control Panels
25. P3500S series Semi-Automatic In-Line Repair High Pressure Specialty Gas Control Panels
27. P3500S series Semi-Automatic In-Line Repair Low Pressure Specialty Gas Control Panels



29.-30. Specialty Gas Manifolds

- 29. P3200 series Specialty Gas Manifolds
- 30. P3300 / P3400 / P3500 series Specialty Gas Manifolds



31.-40. Terminal Gas Control Panels

- 31. P4000 Series Terminal Gas Control Panels
- 33. P4100 Series Terminal Gas Control Panels
- 35. P4200 Series Terminal Gas Control Panels
- 37. P4400 Series Terminal Gas Control Panels
- 39. P4500 Series Terminal Gas Control Panels



41.-46. Other Control Systems

- 41. BS3100 Series Generator Back-Up Control Panel
- 43. P2400 Series Semi-Automatic Control Panel
- 45. SL2500 Series Automatic Switching Cabinet



47.-58. Accessories

- 47. Regulator Protocol Station & Panel Mount
- 48. Header Bars
- 48. Purge Tools
- 50. Check Valves, Filters & Pressure Switches
- 51. Needle Valves, Relief Valves & Diaphragm Valves
- 52. Check Valves, Filters & Pressure Switches
- 53. Gas Pressure Alarms & Flashback Arrestors
- 54. Vacuum Generator & Tube Fittings
- 55. Cylinder Connections
- 56. Wall-Mount Bracket & Pigtails



Company Overview

Genstar Technologies is a global leader in Gas Flow Control Systems for the industrial, specialty gas and medical sectors. We pride ourselves in our ability to provide our customers with high quality, value-added products and services that go beyond the industry standards. As a result, we have a global network of thousands of satisfied customers in over 60 countries.

Our Team

Our highly educated team of engineers, salespeople, technicians, managers, and customer service personnel are dedicated to providing you with products with the highest quality, reliability and performance. We hold the highest standards to our manufacturing processes; our total process management maximizes our production efficiency while ensuring product quality.

We work closely with all of our customers to design products specific to your needs. This includes developing new products, redesigning existing products, and customizing configuration / packaging. It is our priority to foster a strong relationship with each and every customer.

Quality Assurance

All of our products are manufactured under stringent quality control. We are ISO 9001:2001, ISO13485, and API certified. Our products meet UL, CE, SEMI, and various international standards and certifications.

Manufacturing Capabilities

The manufacturing facility is equipped with CNC machines, electro-polishing equipment, and precision automated orbital welding systems, among other features, to ensure the production of the highest quality products.

Clean Room Facilities

Our class 10/100/1000 clean rooms are designed for Ultra High Purity (UHP) products. UHP products undergo precision machining, surface finishing, electro-polishing and passivation. All UHP products are cleaned by 18MΩ DI water in a cascade ultrasonic tank. To ensure the highest UHP product quality, they are then vacuum-dried and double-bagged.

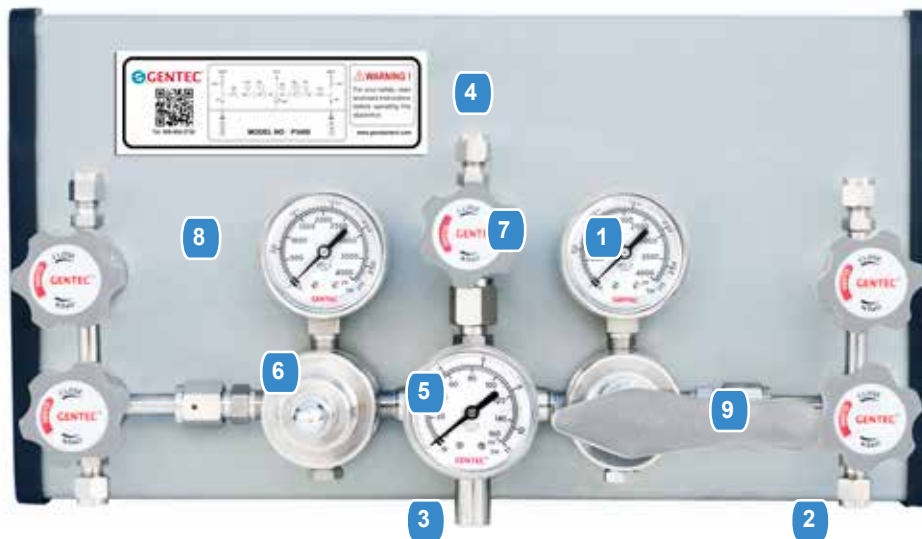

1. Inlet (High) Pressure Gauge

- Fabricated from imported German made Bourdon tubes
- High accuracy and stability

2. Inlet Connection

- Multiple connections available
- Compliant with CGA/BSP/DIN/JIS/GB standards

3. Safety Valve

- Accurate relief of pressure
- Reliable and positive shut-off

4. Outlet Connection

- Multiple connections available

5. Outlet (Low) Pressure Gauge

- Fabricated from imported German made Bourdon tubes
- High accuracy and stability

6. Regulator Body

- Fabricated from high-strength corrosion-resistant material
- Fabricated with advanced CNC machines to produce the highest quality of parts
- Wetted areas are polished to ensure a clean and smooth flow
- 316L & Hastelloy diaphragms produce a metal-to-metal, leak-proof seal

7. Diaphragm Valve

- Designed to withstand temperature and vibration fluctuations
- Quarter turn quick access
- Ergonomically designed control knob for easy adjustment

8. Back Panel

- Powder coated aluminum alloy back plates
- Two piece design for easy installation

9. Priority Handle

- Ergonomic handle
- Priority handle identifies the priority bank
- A 180 degree rotation reassigns the priority bank to opposite bank

Manifolds

1. The P3200 Series Single-Bank Control Panel

Single-bank control panels are suitable for applications where periodic cylinder changes are not critical to the application. The panels are fitted with a main shut off diaphragm valve paired with a vent valve for purging and venting to preserve the purity of gases. They are designed to prevent oxygen, nitrogen, water vapor or other contaminants from entering the system.

2. The P3300 Series Dual-Bank manual Control Panel

P3300 Series Specialty Gas Control Panel is a dual-bank control system, designed to provide accurate control of a variety of gases used in research laboratories, laser gas systems, process analyzers, etc. Vent valves can be integrated for purging to ensure maximum purity of gas and minimize contaminants. A check valve located in between the inlet pressure gauge and regulator at both ends ensures additional safety for the user(s). Available in both stainless steel and brass.

3. The P3400 Series Semi-Automatic Changeover Panel

The P3400 Series Specialty Gas Control Panel is a dual bank semi-automatic changeover system. The semi-automatic panel provides a continuous gas supply without interrupting the system during cylinder(s) replacement. When the primary bank is nearly depleted, a changeover will occur, in which the reserve bank will begin to supply gas to the system. The inlet valve on each bank provides the user additional safety while replacing the cylinder(s) on the empty bank before the next changeover occurs. Available in both stainless steel and brass.

4. The P3500 Series Semi-Automatic Changeover In-line Maintenance Panel

The P3500 Series Specialty Gas Control Panel is a dual-bank semi-automatic changeover system. The system provides a continuous gas supply without interrupting the system during cylinder(s) replacement. When the primary bank is nearly depleted, a changeover will occur, in which the reserve bank will begin to supply gas to the system. One isolation valve on each bank allows the user to replace the cylinder(s) without discontinuing the gas supply. Each regulator is mounted on individual panels for convenient in-line repair and is suitable for applications where an uninterrupted supply gas is critical even while during maintenance and repair. Available in both stainless steel and brass.

5. The PSB/PSSL Single Station Manifold

PSB/PSSL protocol stations are suitable for calibration instrumentation application where specialty gas is used only for calibration purposes and an uninterrupted supply of gas is not required. Designed to provide easy, safe, and fast cylinder exchanges by eliminating the direct connection between the gas regulator and cylinder.

6. The 250 Series Automatic Changeover

A change or drop in delivery pressure can adversely affect instrument performance in some instances. To avoid this problem, an Automatic Changeover manifold may be selected. The 250 series changeover system is a semi-automatic manifold with optional alarm function via indicating contact gauges. A two stage regulation keeps delivery pressure stable.

Point of use Gas Control Panels

Most modern laboratories have multiple instruments that use the same specialty gas but may require different delivery pressures, flowrates or purity levels. Unfortunately, even when a centralized gas distribution system is in place, these varying needs of the instruments are often accommodated by a maze of tubing, line regulators and other accessories that are scattered behind laboratory equipment.

Such disorganization can result in a number of serious problems. First, since regulators and tubing can be bunched together, it is easy to connect the wrong gas to the instrument, resulting in lost or degraded experiments or even damage to the instrument. Second, safety may be compromised since tubing, regulators and traps will not be adequately protected or marked. Third, operating and maintenance costs will increase as the difficulty of identifying and correcting the causes of problems.

A more practical arrangement to eliminate or minimize these problems is to install point-of-use panels designed for dedicated gas service. A typical panel provides a means to control both delivery pressure and flowrate for a gas supplied to an instrument at the point of use. When required, traps can be included on panels as well. Where one instrument requires several gases, a panel can be designed to conveniently regulate the gases. The 4000/4200 Series is an excellent solution.

Gas Delivery Systems

Three key areas of design will determine the quality of the gas performance in a laboratory operation.

1. Source of Supply = Dewars, Gas Cylinders, and Gas Generators
2. Distribution of Gas = Piping System
3. Point of Use Control of Delivery = Terminal Points

Gentec Gas Delivery systems are designed to provide safe, efficient and convenient gas control to the laboratory environment.

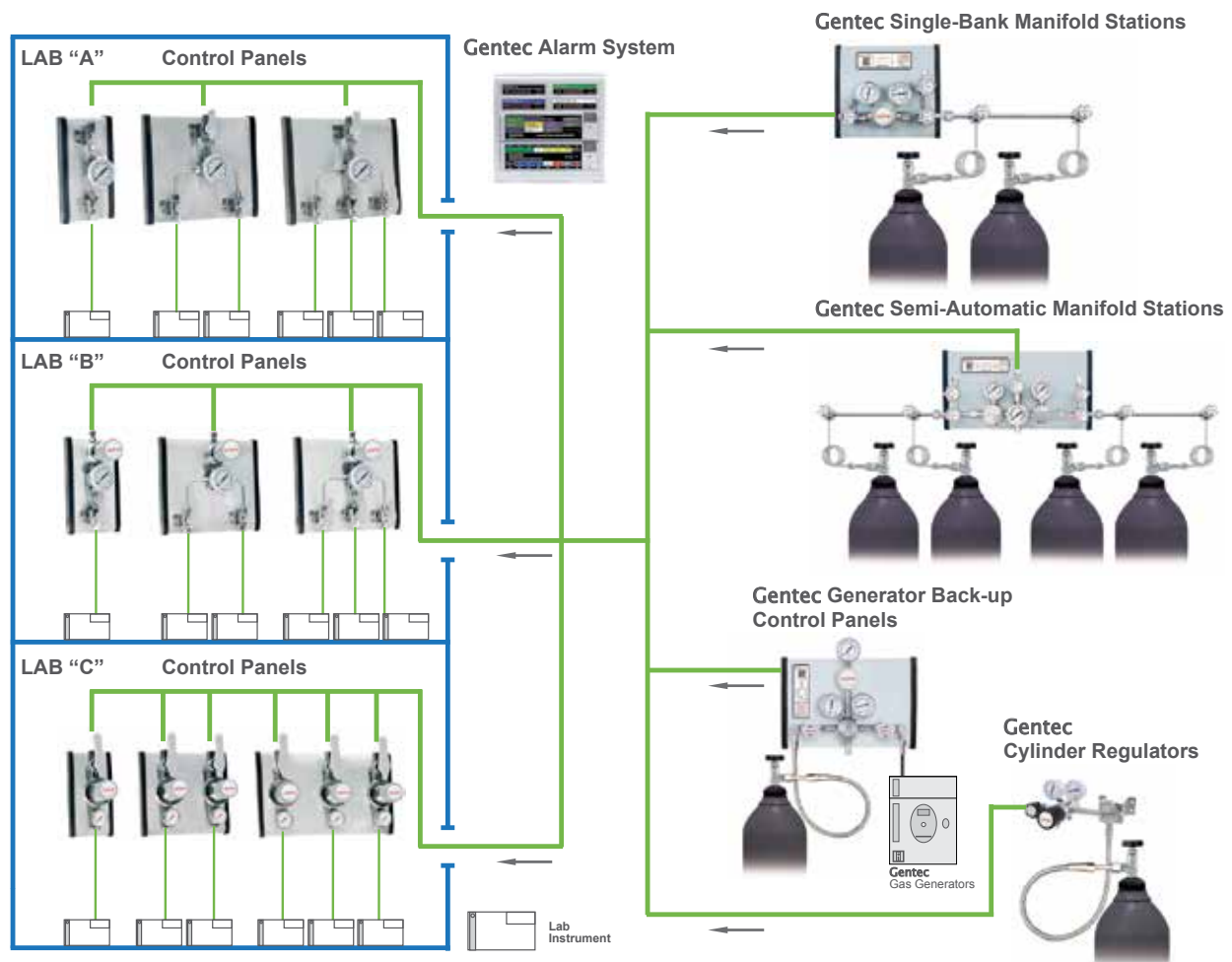

P3200B SERIES

Single-Bank Specialty Gas Control Panels

Specialty Gas Equipment

GENTEC® P3200B Series Specialty Gas Control Panel is a single-bank control system, designed to provide accurate control of a variety of gases used in research laboratories, laser gas systems, process analyzers, etc. Vent valves can be integrated for purging to ensure maximum purity of gas and minimize contaminants.



Product Features

- Single-bank gas supply
- 2" chrome-plated brass gauges
- All parts are mounted on a single panel for easy installation
- Inlet valve(s) for changing cylinder(s) included. Outlet and Vent valves are optional
- Diaphragm valves include an easy-to-read status window (open / close)
- Integrated safety relief valve to ensure additional safety

Specifications

- **Maximum inlet pressure:** 3000, 500 psi
- **Maximum outlet pressure:** 25, 50, 100, 150, 250 psi
- **Operating temperature range:** -40 to 165 °F (-40 to 74 °C)
- **Leak rate:** 2×10^{-8} atm.cc/sec He
- **Cv:** 0.14

Materials of Construction

- **Regulator and valve body:** Chrome-plated brass
- **Regulator seat*:** PU, PTFE
- **Panel:** Aluminium Alloy
- **Panel inlet connections:** 1/4" GENLOK®,
- **Panel outlet connections:** 1/4" GENLOK®

* In the event that the selected material of regulator seat is inappropriate for its applications, Gentec shall reserve the right to appoint an alternative seat material.

Dimensions

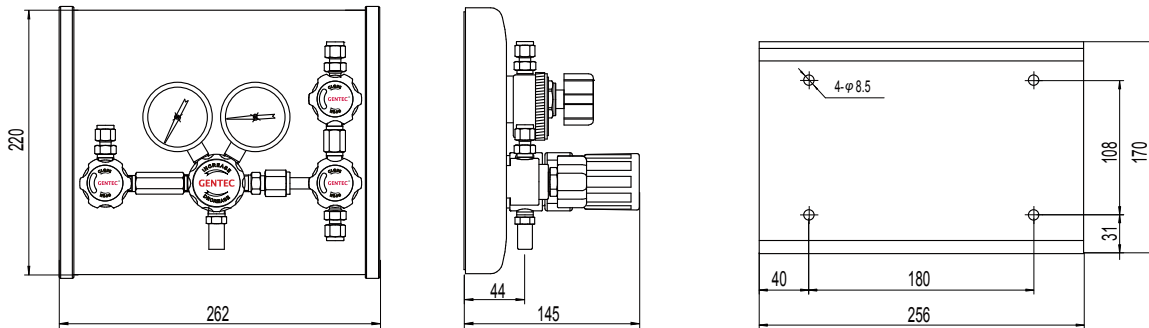

Flow Data

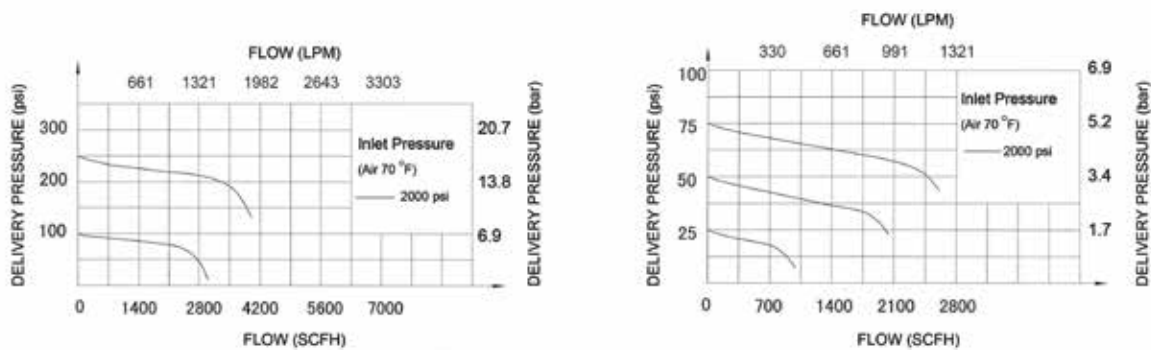

Ordering Information

EX: P32	1	1	B	P -	D	H	P		- N2
Series	Valve Assembly	Inlet Connection	Valve Body	Regulator Seat*	Inlet Pressure	Outlet Pressure	Gauge	Options	Gas Options
• P32	1: Inlet / outlet / vent 2: Inlet / vent 3: Inlet / outlet 4: Inlet only	1: 1/4" Genlok (Vertical) 2: 1/4" FSR (Vertical) 3: 1/2" FSR (Straight) 5: 1/4" NPT (Vertical) 6: 1/4" FNPT (Vertical)	B: Chrome-plated brass	P: PU T: PTFE	D: 3000 psi F: 500 psi	L: 25 psi K: 50 psi I: 100 psi H: 150 psi G: 250 psi	P: psi / bar K: psi / kPa W: No Gauge	Blank: Standard C: Electronic Contact Gauge V: Waste gas disposal	Blank: None AIR: Air HE: Helium O2: Oxygen H2: Hydrogen CH4: Methane CO2: Carbon Dioxide Ar: Argon N2: Nitrogen

*: Please contact GENTEC for regulator seat

P3300B SERIES

Dual-Bank Specialty Gas Control Panels

Specialty Gas Equipment

GENTEC® P3300B Series Specialty Gas Control Panel is a dual-bank control system, designed to provide accurate control of a variety of gases used in research laboratories, laser gas systems, process analyzers, etc. Vent valves can be integrated for purging to ensure maximum purity of gas and minimize contaminants. A check valve located in between the inlet pressure gauge and regulator at both ends ensures additional safety for the user(s). Available in both stainless steel and brass.



Product Features

- Dual-bank gas supply
- 2" chrome-plated brass gauges
- All parts are mounted on a single panel for easy installation
- Inlet valve(s) for changing cylinder(s) included. Outlet and Vent valves are optional
- Diaphragm valves include an easy-to-read status window (open / close)
- Integrated safety relief valve to ensure additional safety

Specifications

- **Maximum inlet pressure:** 3000, 500 psi
- **Maximum outlet pressure:** 25, 50, 100, 150, 250 psi
- **Operating temperature range:** -40 to 165 °F (-40 to 74 °C)
- **Leak rate:** 2×10^{-8} atm.cc/sec He
- **Cv:** 0.14

Materials of Construction

- **Regulator and valve body:** Chrome-plated brass
- **Regulator seat*:** PU, PTFE
- **Panel:** Aluminium Alloy
- **Panel inlet connections:** 1/4" GENLOK®
- **Panel outlet connections:** 1/4" GENLOK®

* In the event that the selected material of regulator seat is inappropriate for its applications, Gentec shall reserve the right to appoint an alternative seat material.

Dimensions

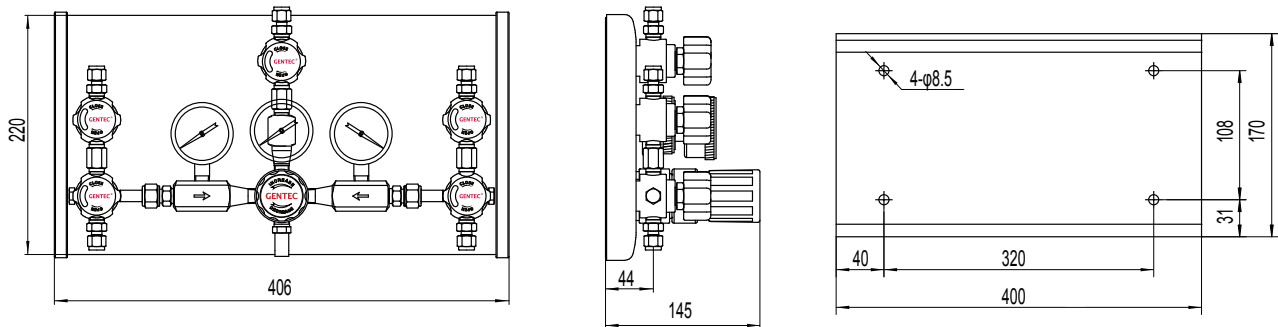

Flow Data

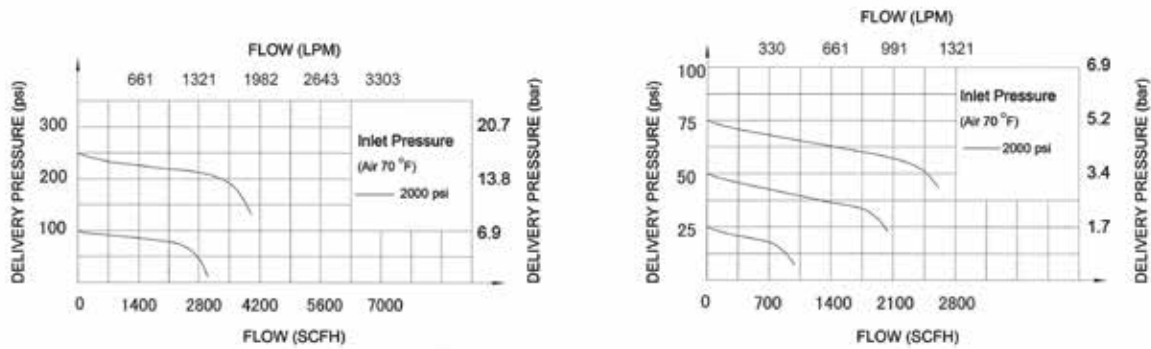

Ordering Information

EX: P33	1	1	B	P -	D	H	P		- N2
Series	Valve Assembly	Inlet Connection	Valve Body	Regulator Seat*	Inlet Pressure	Outlet Pressure	Gauge	Options	Gas Options
• P33	1: Inlet / outlet / vent 2: Inlet / vent 3: Inlet / outlet 4: Inlet only	1: 1/4" Genlok (Vertical) 2: 1/4" FSR (Vertical) 3: 1/2" FSR (Straight) 5: 1/4" NPT (Vertical) 6: 1/4" FNPT (Vertical)	B: Chrome-plated brass	P: PU T: PTFE	D: 3000 psi F: 500 psi	L: 25 psi K: 50 psi I: 100 psi H: 150 psi G: 250 psi	P: psi / bar K: psi / kPa W: No Gauge	Blank: Standard C: Electronic Contact Gauge V: Waste gas disposal	Blank: None AIR: Air HE: Helium O2: Oxygen H2: Hydrogen CH4: Methane CO2: Carbon Dioxide Ar: Argon N2: Nitrogen

*: Please contact GENTEC for regulator seat

P3400B SERIES

Semi-Automatic Specialty Gas Control Panels

Specialty Gas Equipment

GENTEC® P3400B Series Specialty Gas Control Panel is a dual bank semi-automatic changeover system, providing a continuous gas supply without interrupting the system during cylinder(s) replacement. When the primary bank is nearly depleted, a changeover will occur, in which the reserve bank will begin to supply gas to the system. The inlet valve on each bank provides the user additional safety while replacing the cylinder(s) on the empty bank before the next changeover occurs. Available in both stainless steel and brass.



Product Features

- Dual-bank gas supply
- 2" chrome-plated brass gauges
- All parts are mounted on a single panel for easy installation
- Inlet valve(s) for changing cylinder(s) included. Outlet and Vent valves are optional
- Diaphragm valves include an easy-to-read status window (open / close)
- Integrated safety relief valve to ensure additional safety

Specifications

- **Maximum inlet pressure:** 3000, 500 psi
- **Maximum outlet pressure:** 25, 50, 100, 150, 250 psi
- **Operating temperature range:** -40 to 165 °F (-40 to 74 °C)
- **Leak rate:** 2×10^{-8} atm.cc/sec He
- **Cv:** 0.14

Materials of Construction

- **Regulator and valve body:** Chrome-plated brass
- **Regulator seat*:** PU, PTFE
- **Panel:** Aluminium Alloy
- **Panel inlet connections:** 1/4" GENLOK®
- **Panel outlet connections:** 1/4" GENLOK®

* In the event that the selected material of regulator seat is inappropriate for its applications, Gentec shall reserve the right to appoint an alternative seat material.

Dimensions

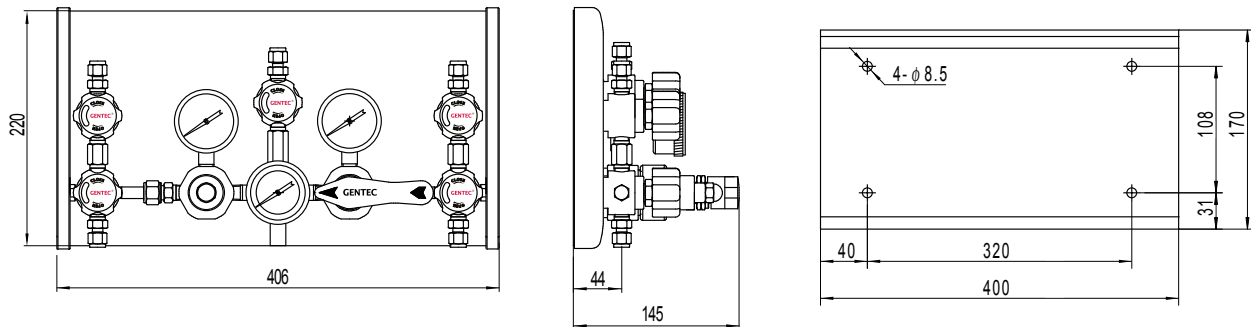

Flow Data

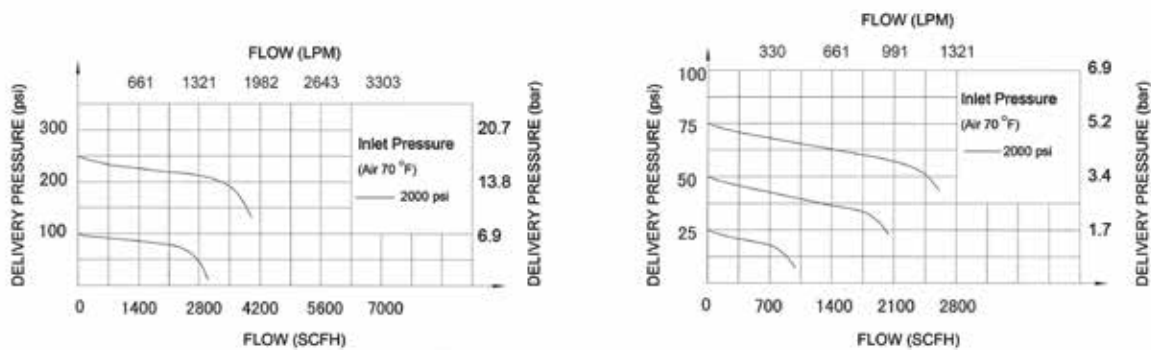

Ordering Information

EX: P34	1	1	B	P -	D	H	P		- N2
Series	Valve Assembly	Inlet Connection	Valve Body	Regulator Seat*	Inlet Pressure	Outlet Pressure	Gauge	Options	Gas Options
• P34	1: Inlet / outlet / vent 2: Inlet / vent 3: Inlet / outlet 4: Inlet only	1: 1/4" Genlok (Vertical) 2: 1/4" FSR (Vertical) 3: 1/2" FSR (Straight) 5: 1/4" NPT (Vertical) 6: 1/4" FNPT (Vertical)	B: Chrome-plated brass	P: PU T: PTFE	D: 3000 psi F: 500 psi	L: 25 psi K: 50 psi I: 100 psi H: 150 psi G: 250 psi	P: psi / bar K: psi / kPa W: No Gauge	Blank: Standard C: Electronic Contact Gauge V: Waste gas disposal	Blank: None AIR: Air HE: Helium O2: Oxygen H2: Hydrogen CH4: Methane CO2: Carbon Dioxide Ar: Argon N2: Nitrogen

*: Please contact GENTEC for regulator seat

P3500B SERIES

Semi-Automatic In-Line Repair Specialty Gas Control Panels

Specialty Gas Equipment

GENTEC® P3500 Series Specialty Gas Control Panel is a dual-bank semi-automatic changeover system, providing a continuous gas supply without interrupting the system during cylinder(s) replacement. When the primary bank is nearly depleted, a changeover will occur, in which the reserve bank will begin to supply gas to the system. One isolation valve on each bank allows the user to replace the cylinder(s) without discontinuing the gas supply. Each regulator is mounted on individual panels for convenient in-line repair. Available in both stainless steel and brass.



Product Features

- Dual-bank gas supply
- 2" chrome-plated brass gauges
- All parts are mounted on a single panel for easy installation
- Inlet valve(s) for changing cylinder(s) included. Outlet and Vent valves are optional
- Diaphragm valves include an easy-to-read status window (open / close)
- Integrated safety relief valve to ensure additional safety

Specifications

- **Maximum inlet pressure:** 3000, 500 psi
- **Maximum outlet pressure:** 25, 50, 100, 150, 250 psi
- **Operating temperature range:** -40 to 165 °F (-40 to 74 °C)
- **Leak rate:** 2×10^{-8} atm.cc/sec He
- **Cv:** 0.14

Materials of Construction

- **Regulator and valve body:** Chrome-plated brass
- **Regulator seat*:** PU, PTFE
- **Panel:** Aluminium Alloy
- **Panel inlet connections:** 1/4" GENLOK®
- **Panel outlet connections:** 1/4" GENLOK®

* In the event that the selected material of regulator seat is inappropriate for its applications, Gentec shall reserve the right to appoint an alternative seat material.

Dimensions

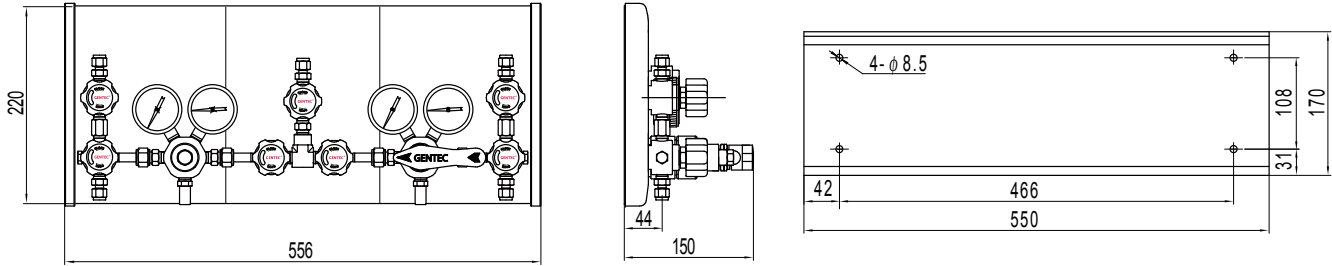

Flow Data

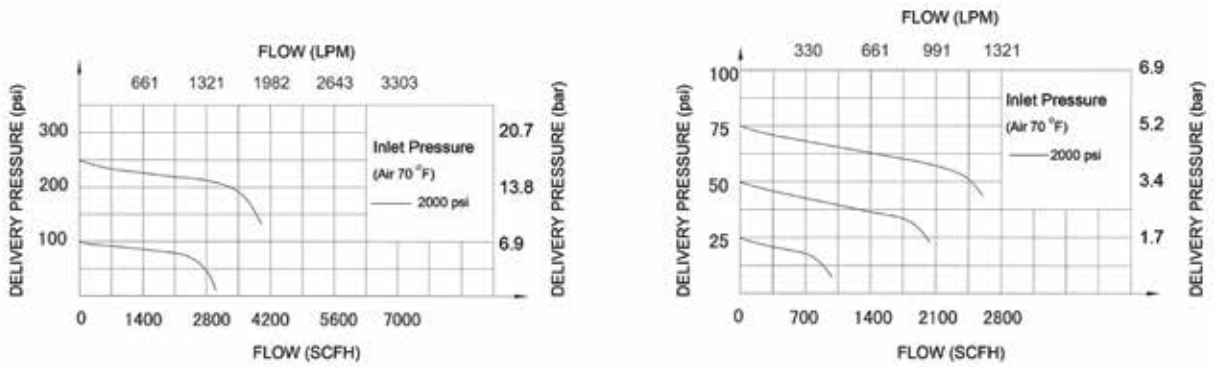

Ordering Information

EX: P35	1	1	B	P -	D	H	P		- N2
Series	Valve Assembly	Inlet Connection	Valve Body	Regulator Seat*	Inlet Pressure	Outlet Pressure	Gauge	Options	Gas Options
• P35	1: Inlet / outlet / vent 2: Inlet / vent 3: Inlet / outlet 4: Inlet only	1: 1/4" Genlok (Vertical) 2: 1/4" FSR (Vertical) 3: 1/2" FSR (Straight) 5: 1/4" NPT (Vertical) 6: 1/4" FNPT (Vertical)	B: Chrome-plated brass	P: PU T: PTFE	D: 3000 psi F: 500 psi	L: 25 psi K: 50 psi I: 100 psi H: 150 psi G: 250 psi	P: psi / bar K: psi / kPa W: No Gauge	Blank: Standard C: Electronic Contact Gauge V: Waste gas disposal	Blank: None AIR: Air HE: Helium O2: Oxygen H2: Hydrogen CH4: Methane CO2: Carbon Dioxide Ar: Argon N2: Nitrogen

*: Please contact GENTEC for regulator seat

P3200S SERIES

Single-Bank High Pressure Specialty Gas Control Panels

Specialty Gas Equipment

GENTEC® P3200S Series Specialty Gas Control Panel is a single-bank control system, designed to provide accurate control of a variety of gases used in research laboratories, laser gas systems, process analyzers, etc. Vent valves can be integrated for purging to ensure maximum purity of gas and minimize contaminants.



Product Features

- Single-bank gas supply
- 2" stainless steel pressure gauges
- All parts are mounted on a single panel for easy installation
- Inlet valve(s) for changing cylinder(s) included. Outlet and Vent valves are optional
- Diaphragm valves include an easy-to-read status window (open / close)
- Integrated safety relief valve to ensure additional safety
- Diaphragm valve connections are orbital welded to minimize contamination and leakage

Specifications

- **Maximum inlet pressure:** 3000, 2200 psi
- **Maximum outlet pressure:** 25, 50, 100, 150, 250 psi
- **Operating temperature range:** -40 to 165 °F (-40 to 74 °C)
- **Leak rate:** 2×10^{-8} atm.cc/sec He
- **Cv:** 0.14

Materials of Construction

- **Regulator and valve body:** Stainless steel
- **Regulator seat*:** PU, PTFE, PCTFE
- **Panel:** Aluminium Alloy
- **Panel inlet connections:** 1/4" GENLOK®, 1/4" FSR, 1/2" FSR
- **Panel outlet connections:** 1/4" GENLOK®, 1/4" FSR

* In the event that the selected material of regulator seat is inappropriate for its applications, Gentec shall reserve the right to appoint an alternative seat material.

Dimensions

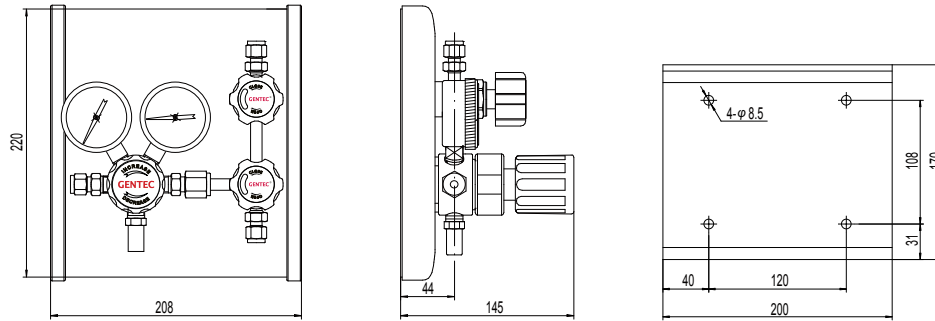

Flow Data

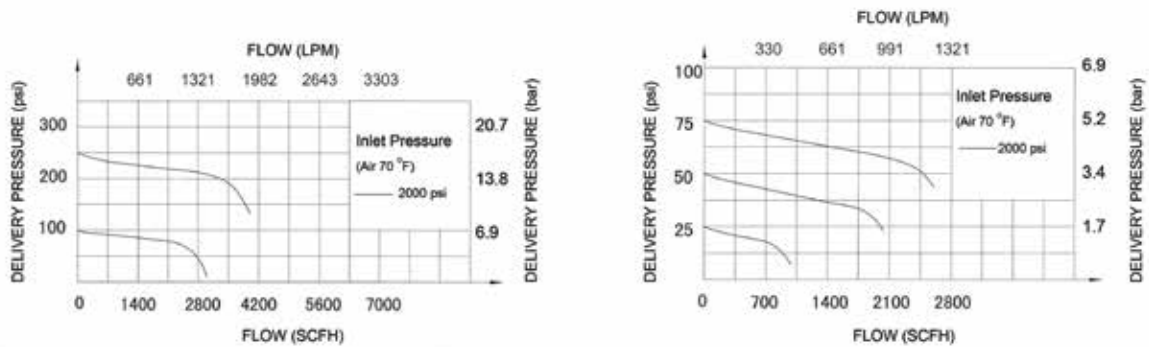

Ordering Information

EX: P32	1	1	S	P -	D	H	P		- N2
Series	Valve Assembly	Inlet Connection	Valve Body	Regulator Seat*	Inlet Pressure	Outlet Pressure	Gauge	Options	Gas Options
• P32	1: Inlet / outlet / vent 2: Inlet / vent 3: Inlet / outlet 4: Inlet only	1: 1/4" Genlok (Vertical) 2: 1/4" FSR (Vertical) 3: 1/2" FSR (Straight) 5: 1/4" NPT (Vertical) 6: 1/4" FNPT (Vertical)	S: Stainless steel	P: PU T: PTFE K: PCTFE	D: 3000 psi X: 2200 psi	L: 25 psi K: 50 psi I: 100 psi H: 150 psi G: 250 psi	P: psi / bar K: psi / kPa W: No Gauge	Blank: Standard C: Electronic Contact Gauge V: Waste gas disposal	Blank: None AIR: Air HE: Helium O2: Oxygen H2: Hydrogen CH4: Methane CO2: Carbon Dioxide Ar: Argon N2: Nitrogen

*: Please contact GENTEC for regulator seat

P3200S SERIES

Single-Bank Low Pressure Specialty Gas Control Panels

Specialty Gas Equipment

GENTEC® P3200S Series Specialty Gas Control Panel is a single-bank control system, designed to provide accurate control of a variety of gases used in research laboratories, laser gas systems, process analyzers, etc. Vent valves can be integrated for purging to ensure maximum purity of gas and minimize contaminants.



Product Features

- Single-bank gas supply
- 2" stainless steel pressure gauges
- All parts are mounted on a single panel for easy installation
- Inlet valve(s) for changing cylinder(s) included. Outlet and Vent valves are optional
- Diaphragm valves include an easy-to-read status window (open / close)
- Integrated safety relief valve to ensure additional safety
- Diaphragm valve connections are orbital welded to minimize contamination and leakage

Specifications

- **Maximum inlet pressure:** 500, 250 psi
- **Maximum outlet pressure:** 25, 50, 100, 150 psi
- **Operating temperature range:** -40 to 165 °F (-40 to 74 °C)
- **Leak rate:** 2×10^{-8} atm.cc/sec He
- **Cv:** 0.2

Materials of Construction

- **Regulator and valve body:** Stainless steel
- **Regulator seat:** Neoprene
- **Panel:** Aluminium Alloy
- **Panel inlet connections:** 1/4" GENLOK®, 1/4" FSR, 1/2" FSR
- **Panel outlet connections:** 1/4" GENLOK®, 1/4" FSR

Dimensions

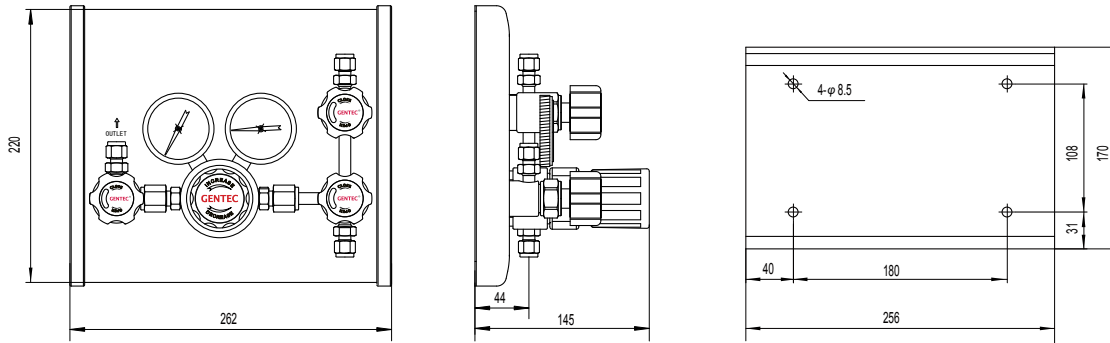

Flow Data

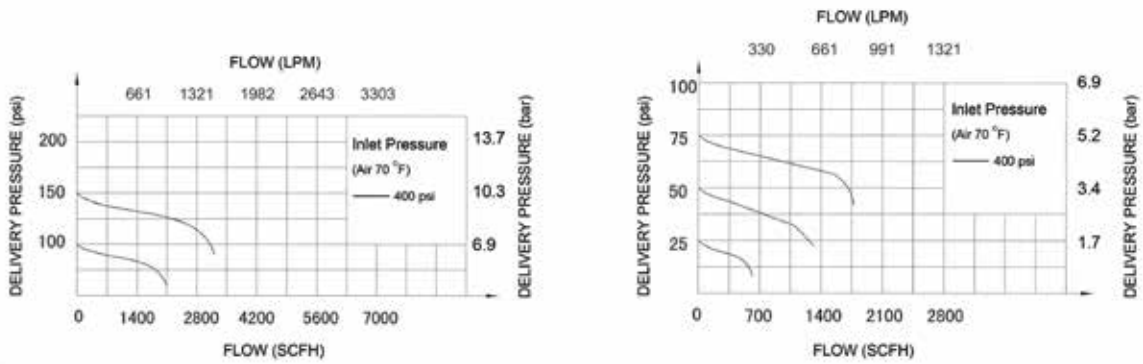

Ordering Information

EX: P32	1	1	S	N -	F	H	P	Options	- NH4
Series	Valve Assembly	Inlet Connection	Valve Body	Regulator Seat*	Inlet Pressure	Outlet Pressure	Gauge		Gas Options
• P32	1: Inlet / outlet / vent 2: Inlet / vent 3: Inlet / outlet 4: Inlet only	1: 1/4" Genlok (Vertical) 2: 1/4" FSR (Vertical) 3: 1/2" FSR (Straight) 5: 1/4" NPT (Vertical) 6: 1/4" FNPT (Vertical)	S: Stainless steel	N: Neoprene	F: 500 psi G: 250 psi	L: 25 psi K: 50 psi I: 100 psi H: 150 psi	P: psi / bar K: psi / kPa W: No Gauge	Blank: Standard C: Electronic Contact Gauge V: Waste gas disposal	Blank: None NH4: Ammonia C2H2: Acetylene

*: Please contact GENTEC for regulator seat

P3300S SERIES

Dual-Bank High Pressure Specialty Gas Control Panels

Specialty Gas Equipment

GENTEC® P3300S Series Specialty Gas Control Panel is a dual-bank control system, designed to provide accurate control of a variety of gases used in research laboratories, laser gas systems, process analyzers, etc. Vent valves can be integrated for purging to ensure maximum purity of gas and minimize contaminants. A check valve located in between the inlet pressure gauge and regulator at both ends ensures additional safety for the user(s). Available in both stainless steel and brass.

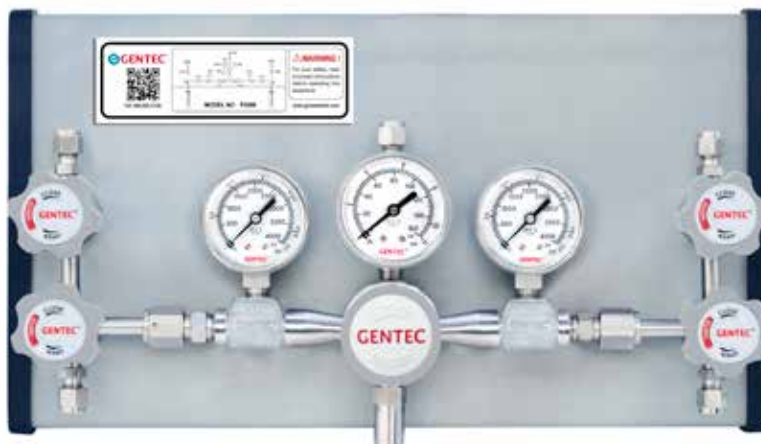

Product Features

- Dual-bank gas supply
- 2" stainless steel pressure gauges
- All parts are mounted on a single panel for easy installation
- Inlet valve(s) for changing cylinder(s) included. Outlet and Vent valves are optional
- Diaphragm valves include an easy-to-read status window (open / close)
- Integrated safety relief valve to ensure additional safety
- Diaphragm valve connections are orbital welded to minimize contamination and leakage

Specifications

- **Maximum inlet pressure:** 3000, 2200 psi
- **Maximum outlet pressure:** 25, 50, 100, 150, 250 psi
- **Operating temperature range:** -40 to 165 °F (-40 to 74 °C)
- **Leak rate:** 2×10^{-8} atm.cc/sec He
- **Cv:** 0.14

Materials of Construction

- **Regulator and valve body:** Stainless steel
- **Regulator seat*:** PU, PTFE, PCTFE
- **Panel:** Aluminium Alloy
- **Panel inlet connections:** 1/4" GENLOK®, 1/4" FSR, 1/2" FSR
- **Panel outlet connections:** 1/4" GENLOK®, 1/4" FSR

* In the event that the selected material of regulator seat is inappropriate for its applications, Gentec shall reserve the right to appoint an alternative seat material.

Dimensions

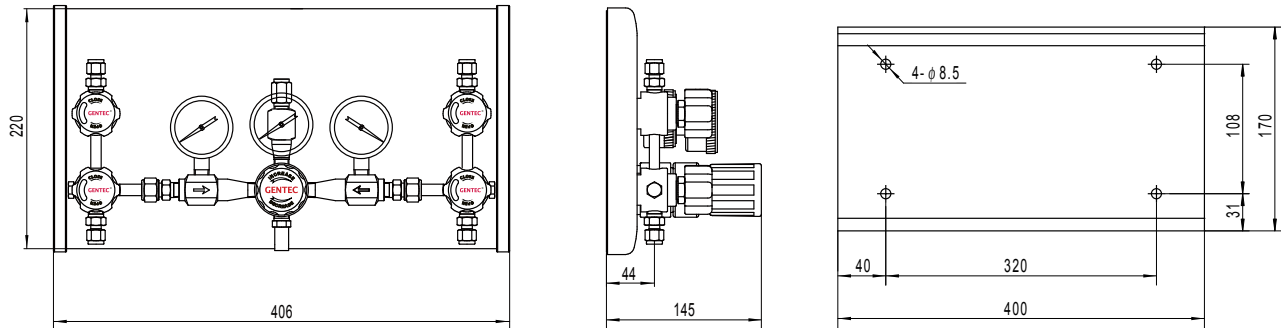

Flow Data

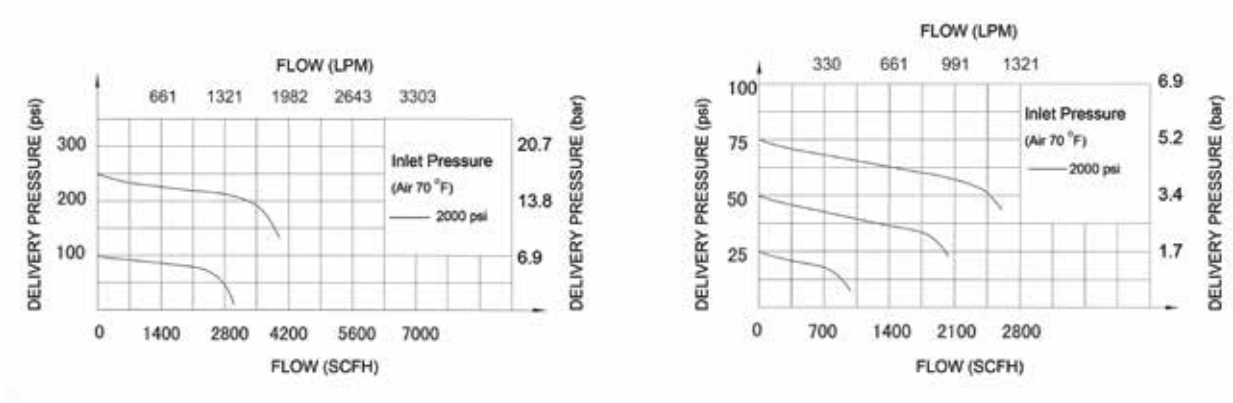

Ordering Information

EX: P33	1	1	S	P -	D	H	P		- N2
Series	Valve Assembly	Inlet Connection	Valve Body	Regulator Seat*	Inlet Pressure	Outlet Pressure	Gauge	Options	Gas Options
• P33	1: Inlet / outlet / vent 2: Inlet / vent 3: Inlet / outlet 4: Inlet only	1: 1/4" Genlok (Vertical) 2: 1/4" FSR (Vertical) 3: 1/2" FSR (Straight) 5: 1/4" NPT (Vertical) 6: 1/4" FNPT (Vertical)	S: Stainless steel	P: PU T: PTFE K: PCTFE	D: 3000 psi X: 2200 psi	L: 25 psi K: 50 psi I: 100 psi H: 150 psi G: 250 psi	P: psi / bar K: psi / kPa W: No Gauge	Blank: Standard C: Electronic Contact Gauge V: Waste gas disposal	Blank: None AIR: Air HE: Helium O2: Oxygen H2: Hydrogen CH4: Methane CO2: Carbon Dioxide Ar: Argon N2: Nitrogen

*: Please contact GENTEC for regulator seat

P3300S SERIES

Dual-Bank Low Pressure Specialty Gas Control Panels

Specialty Gas Equipment

GENTEC® P3300S Series Specialty Gas Control Panel is a dual-bank control system, designed to provide accurate control of a variety of gases used in research laboratories, laser gas systems, process analyzers, etc. Vent valves can be integrated for purging to ensure maximum purity of gas and minimize contaminants. A check valve located in between the inlet pressure gauge and regulator at both ends ensures additional safety for the user(s). Available in both stainless steel and brass.



Product Features

- Dual-bank gas supply
- 2" stainless steel pressure gauges
- All parts are mounted on a single panel for easy installation
- Inlet valve(s) for changing cylinder(s) included. Outlet and Vent valves are optional
- Diaphragm valves include an easy-to-read status window (open / close)
- Integrated safety relief valve to ensure additional safety
- Diaphragm valve connections are orbital welded to minimize contamination and leakage

Specifications

- **Maximum inlet pressure:** 500, 250 psi
- **Maximum outlet pressure:** 25, 50, 100, 150 psi
- **Operating temperature range:** -40 to 165 °F (-40 to 74 °C)
- **Leak rate:** 2×10^{-8} atm.cc/sec He
- **Cv:** 0.2

Materials of Construction

- **Regulator and valve body:** Stainless steel
- **Regulator seat:** Neoprene
- **Panel:** Aluminium Alloy
- **Panel inlet connections:** 1/4" GENLOK®, 1/4" FSR, 1/2" FSR
- **Panel outlet connections:** 1/4" GENLOK®, 1/4" FSR

Dimensions

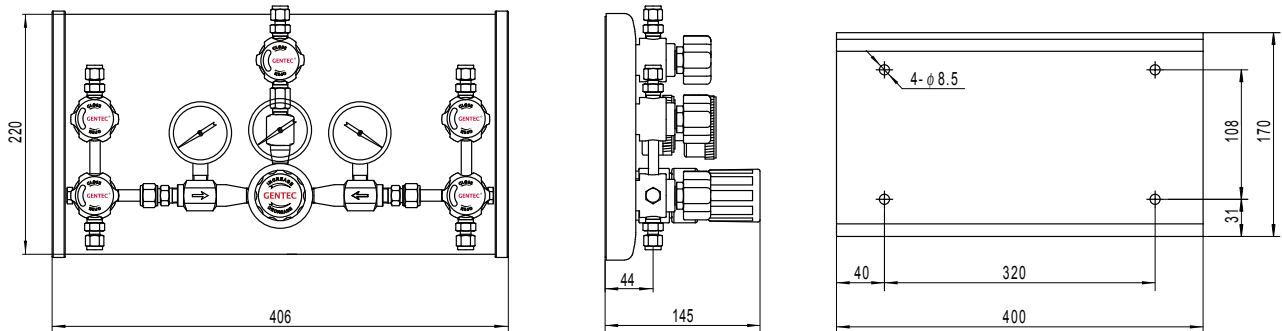

Flow Data

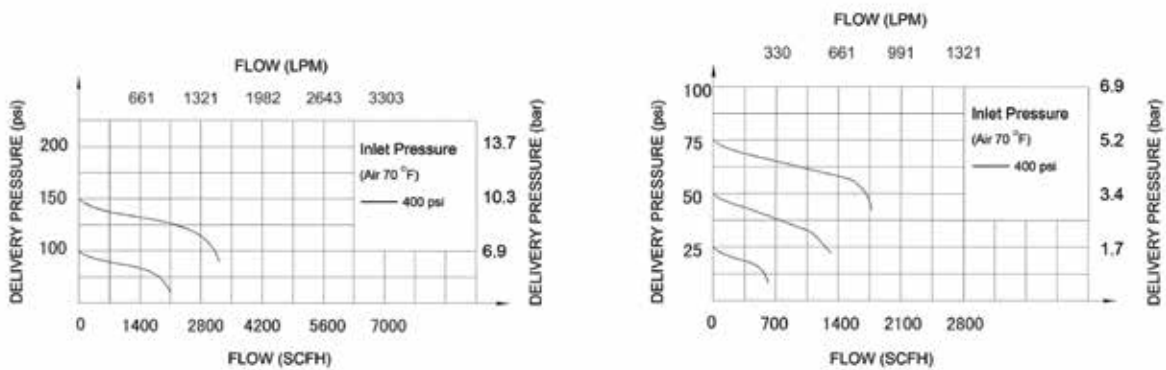

Ordering Information

EX: P33	1	1	S	N -	F	H	P	Options	- N2
Series	Valve Assembly	Inlet Connection	Valve Body	Regulator Seat*	Inlet Pressure	Outlet Pressure	Gauge		Gas Options
• P33	1: Inlet / outlet / vent 2: Inlet / vent 3: Inlet / outlet 4: Inlet only	1: 1/4" Genlok (Vertical) 2: 1/4" FSR (Vertical) 3: 1/2" FSR (Straight) 5: 1/4" NPT (Vertical) 6: 1/4" FNPT (Vertical)	S: Stainless steel	N: Neoprene	F: 500 psi G: 250 psi	L: 25 psi K: 50 psi I: 100 psi H: 150 psi G: 250 psi	P: psi / bar K: psi / kPa W: No Gauge	Blank: Standard C: Electronic Contact Gauge V: Waste gas disposal	Blank: None NH4: Ammonia C2H2: Acetylene

*: Please contact GENTEC for regulator seat

P3400S SERIES

Semi-Automatic High Pressure Specialty Gas Control Panels

Specialty Gas Equipment

GENTEC® P3400S Series Specialty Gas Control Panel is a dual bank semi-automatic changeover system, providing a continuous gas supply without interrupting the system during cylinder(s) replacement. When the primary bank is nearly depleted, a changeover will occur, in which the reserve bank will begin to supply gas to the system. The inlet valve on each bank provides the user additional safety while replacing the cylinder(s) on the empty bank before the next changeover occurs. Available in both stainless steel and brass.



Product Features

- Dual-bank gas supply
- 2" stainless steel pressure gauges
- All parts are mounted on a single panel for easy installation
- Inlet valve(s) for changing cylinder(s) included. Outlet and Vent valves are optional
- Diaphragm valves include an easy-to-read status window (open / close)
- Integrated safety relief valve to ensure additional safety
- Diaphragm valve connections are orbital welded to minimize contamination and leakage

Specifications

- **Maximum inlet pressure:** 3000, 2200 psi
- **Maximum outlet pressure:** 25, 50, 100, 150, 250 psi
- **Operating temperature range:** -40 to 165 °F (-40 to 74 °C)
- **Leak rate:** 2×10^{-8} atm.cc/sec He
- **Cv:** 0.14

Materials of Construction

- **Regulator and valve body:** Stainless steel
- **Regulator seat*:** PU, PTFE, PCTFE
- **Panel:** Aluminium Alloy
- **Panel inlet connections:** 1/4" GENLOK®, 1/4" FSR, 1/2" FSR
- **Panel outlet connections:** 1/4" GENLOK®, 1/4" FSR

* In the event that the selected material of regulator seat is inappropriate for its applications, Gentec shall reserve the right to appoint an alternative seat material.

Dimensions

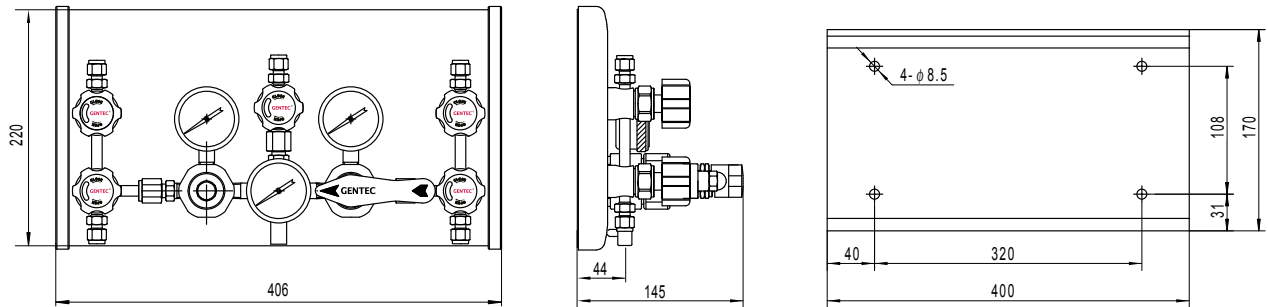

Flow Data

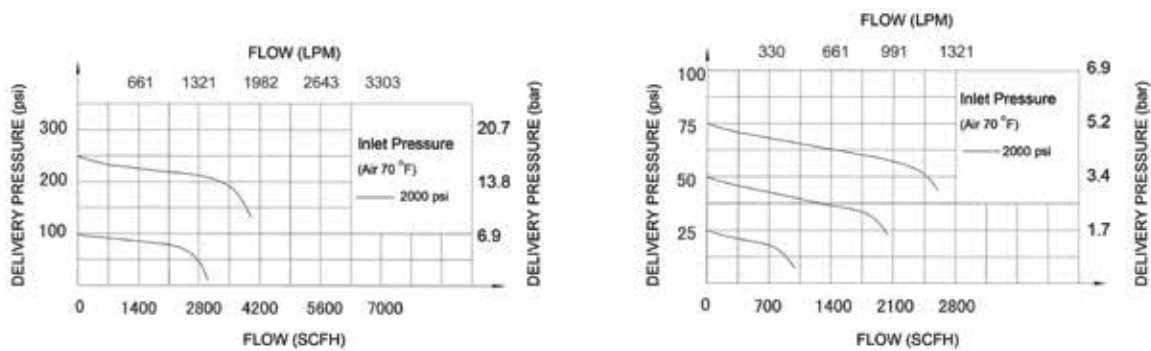

Ordering Information

EX: P34	1	1	S	P -	D	H	P		- N2
Series	Valve Assembly	Inlet Connection	Valve Body	Regulator Seat*	Inlet Pressure	Outlet Pressure	Gauge	Options	Gas Options
• P34	1: Inlet / outlet / vent 2: Inlet / vent 3: Inlet / outlet 4: Inlet only	1: 1/4" Genlok (Vertical) 2: 1/4" FSR (Vertical) 3: 1/2" FSR (Straight) 5: 1/4" NPT (Vertical) 6: 1/4" FNPT (Vertical)	S: Stainless steel	P: PU T: PTFE K: PCTFE	D: 3000 psi X: 2200 psi	L: 25 psi K: 50 psi I: 100 psi H: 150 psi G: 250 psi	P: psi / bar K: psi / kPa W: No Gauge	Blank: Standard C: Electronic Contact Gauge V: Waste gas disposal	Blank: None AIR: Air HE: Helium O2: Oxygen H2: Hydrogen CH4: Methane CO2: Carbon Dioxide Ar: Argon N2: Nitrogen

*: Please contact GENTEC for regulator seat

P3400S SERIES

Semi-Automatic Low Pressure Specialty Gas Control Panels

Specialty Gas Equipment

GENTEC® P3400S Series Specialty Gas Control Panel is a dual bank semi-automatic changeover system, providing a continuous gas supply without interrupting the system during cylinder(s) replacement. When the primary bank is nearly depleted, a changeover will occur, in which the reserve bank will begin to supply gas to the system. The inlet valve on each bank provides the user additional safety while replacing the cylinder(s) on the empty bank before the next changeover occurs. Available in both stainless steel and brass.



Product Features

- Dual-bank gas supply
- 2" stainless steel pressure gauges
- All parts are mounted on a single panel for easy installation
- Inlet valve(s) for changing cylinder(s) included. Outlet and Vent valves are optional
- Diaphragm valves include an easy-to-read status window (open / close)
- Integrated safety relief valve to ensure additional safety
- Diaphragm valve connections are orbital welded to minimize contamination and leakage

Specifications

- **Maximum inlet pressure:** 500, 250 psi
- **Maximum outlet pressure:** 25, 50, 100, 150 psi
- **Operating temperature range:** -40 to 165 °F (-40 to 74 °C)
- **Leak rate:** 2×10^{-8} atm.cc/sec He
- **Cv:** 0.2

Materials of Construction

- **Regulator and valve body:** Stainless steel
- **Regulator seat:** Neoprene
- **Panel:** Aluminium Alloy
- **Panel inlet connections:** 1/4" GENLOK®, 1/4" FSR, 1/2" FSR
- **Panel outlet connections:** 1/4" GENLOK®, 1/4" FSR

Dimensions

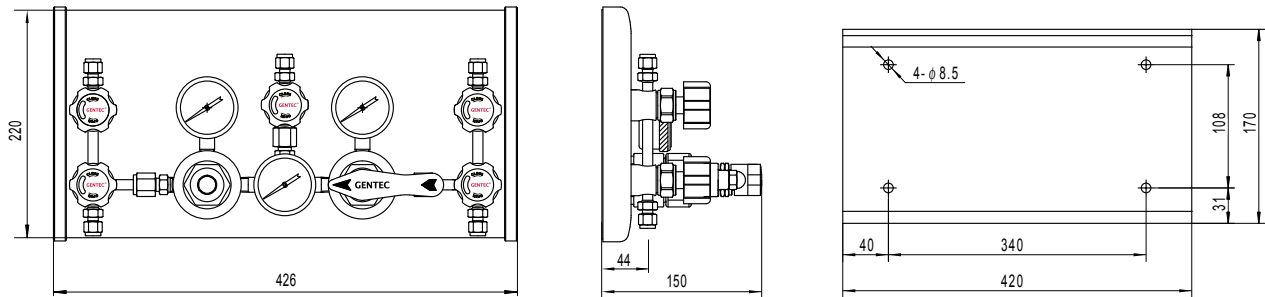

Flow Data

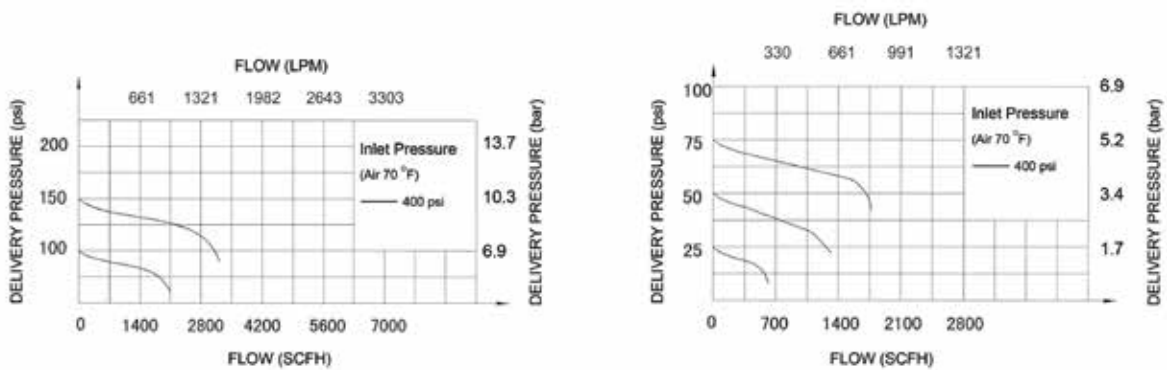

Ordering Information

EX: P34	1	1	S	N -	F	H	P	Options	- N2
Series	Valve Assembly	Inlet Connection	Valve Body	Regulator Seat*	Inlet Pressure	Outlet Pressure	Gauge		Gas Options
• P34	1: Inlet / outlet / vent 2: Inlet / vent 3: Inlet / outlet 4: Inlet only	1: 1/4" Genlok (Vertical) 2: 1/4" FSR (Vertical) 3: 1/2" FSR (Straight) 5: 1/4" NPT (Vertical) 6: 1/4" FNPT (Vertical)	S: Stainless steel	N: Neoprene	F: 500 psi G: 250 psi	L: 25 psi K: 50 psi I: 100 psi H: 150 psi G: 250 psi	P: psi / bar K: psi / kPa W: No Gauge	Blank: Standard C: Electronic Contact Gauge V: Waste gas disposal	Blank: None NH4: Ammonia C2H2: Acetylene

*: Please contact GENTEC for regulator seat

P3500S SERIES

Semi-Automatic In-Line Repair High Pressure Specialty Gas Control Panels

Specialty Gas Equipment

GENTEC® P3500S Series Specialty Gas Control Panel is a dual-bank semi-automatic changeover system, providing a continuous gas supply without interrupting the system during cylinder(s) replacement. When the primary bank is nearly depleted, a changeover will occur, in which the reserve bank will begin to supply gas to the system. One isolation valve on each bank allows the user to replace the cylinder(s) without discontinuing the gas supply. Each regulator is mounted on individual panels for convenient in-line repair. Available in both stainless steel and brass.



Product Features

- Dual-bank gas supply
- 2" stainless steel pressure gauges
- All parts are mounted on a single panel for easy installation
- Inlet valve(s) for changing cylinder(s) included. Outlet and Vent valves are optional
- Diaphragm valves include an easy-to-read status window (open / close)
- Integrated safety relief valve to ensure additional safety
- Diaphragm valve connections are orbital welded to minimize contamination and leakage

Specifications

- **Maximum inlet pressure:** 3000, 2200 psi
- **Maximum outlet pressure:** 25, 50, 100, 150, 250 psi
- **Operating temperature range:** -40 to 165 °F (-40 to 74 °C)
- **Leak rate:** 2×10^{-8} atm.cc/sec He
- **Cv:** 0.14

Materials of Construction

- **Regulator and valve body:** Stainless steel
- **Regulator seat*:** PU, PTFE, PCTFE
- **Panel:** Aluminium Alloy
- **Panel inlet connections:** 1/4" GENLOK®, 1/4" FSR, 1/2" FSR
- **Panel outlet connections:** 1/4" GENLOK®, 1/4" FSR

* In the event that the selected material of regulator seat is inappropriate for its applications, Gentec shall reserve the right to appoint an alternative seat material.

Dimensions

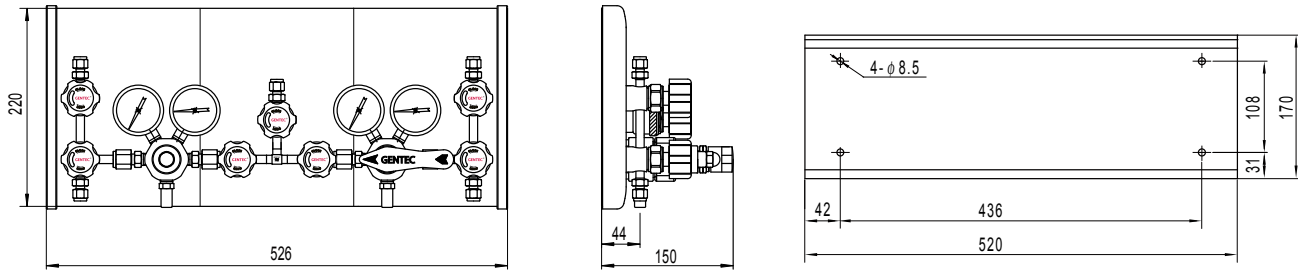

Flow Data

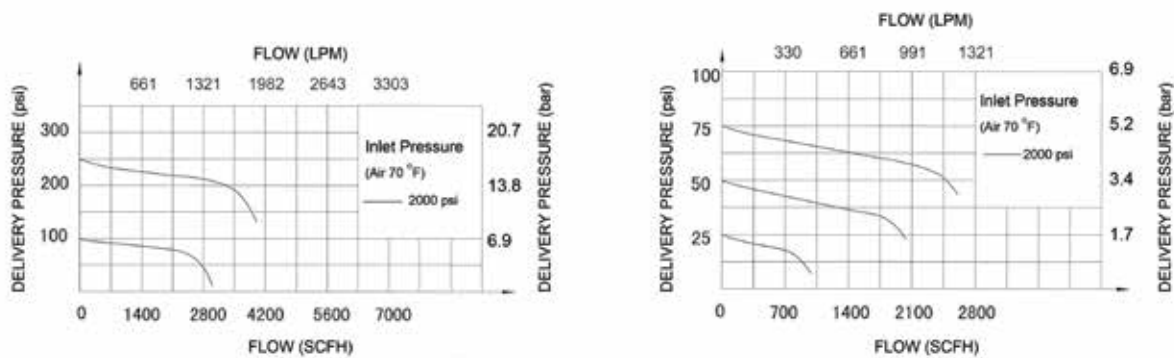

Ordering Information

EX: P35	1	1	S	P -	D	H	P		- N2
Series	Valve Assembly	Inlet Connection	Valve Body	Regulator Seat*	Inlet Pressure	Outlet Pressure	Gauge	Options	Gas Options
• P35	1: Inlet / outlet / vent 2: Inlet / vent 3: Inlet / outlet 4: Inlet only	1: 1/4" Genlok (Vertical) 2: 1/4" FSR (Vertical) 3: 1/2" FSR (Straight) 5: 1/4" NPT (Vertical) 6: 1/4" FNPT (Vertical)	S: Stainless steel	P: PU T: PTFE K: PCTFE	D: 3000 psi X: 2200 psi	L: 25 psi K: 50 psi I: 100 psi H: 150 psi G: 250 psi	P: psi / bar K: psi / kPa W: No Gauge	Blank: Standard C: Electronic Contact Gauge V: Waste gas disposal	Blank: None AIR: Air HE: Helium O2: Oxygen H2: Hydrogen CH4: Methane CO2: Carbon Dioxide Ar: Argon N2: Nitrogen

*: Please contact GENTEC for regulator seat

P3500S SERIES

Semi-Automatic In-Line Repair Low Pressure Specialty Gas Control Panels

Specialty Gas Equipment

GENTEC® P3500S Series Specialty Gas Control Panel is a dual-bank semi-automatic changeover system, providing a continuous gas supply without interrupting the system during cylinder(s) replacement. When the primary bank is nearly depleted, a changeover will occur, in which the reserve bank will begin to supply gas to the system. One isolation valve on each bank allows the user to replace the cylinder(s) without discontinuing the gas supply. Each regulator is mounted on individual panels for convenient in-line repair. Available in both stainless steel and brass.



Product Features

- Dual-bank gas supply
- 2" stainless steel pressure gauges
- All parts are mounted on a single panel for easy installation
- Inlet valve(s) for changing cylinder(s) included. Outlet and Vent valves are optional
- Diaphragm valves include an easy-to-read status window (open / close)
- Integrated safety relief valve to ensure additional safety
- Diaphragm valve connections are orbital welded to minimize contamination and leakage

Specifications

- **Maximum inlet pressure:** 500, 250 psi
- **Maximum outlet pressure:** 25, 50, 100, 150 psi
- **Operating temperature range:** -40 to 165 °F (-40 to 74 °C)
- **Leak rate:** 2×10^{-8} atm.cc/sec He
- **Cv:** 0.2

Materials of Construction

- **Regulator and valve body:** Stainless steel
- **Regulator seat:** Neoprene
- **Panel:** Aluminium alloy
- **Panel inlet connections:** 1/4" GENLOK®, 1/4" FSR, 1/2" FSR
- **Panel outlet connections:** 1/4" GENLOK®, 1/4" FSR

Dimensions

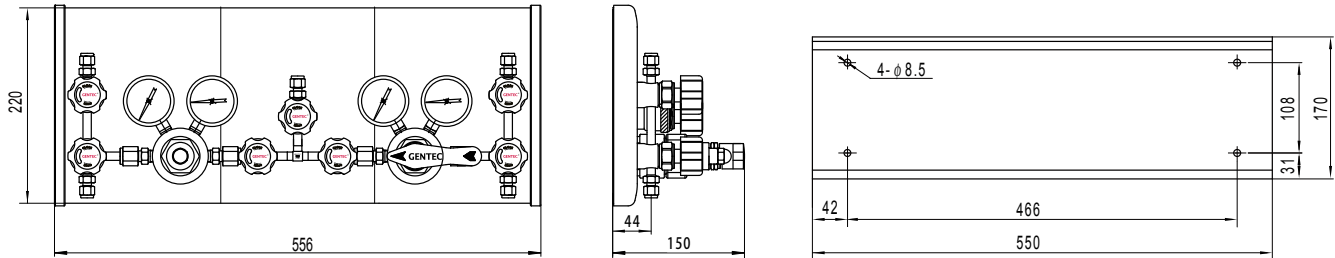

Flow Data

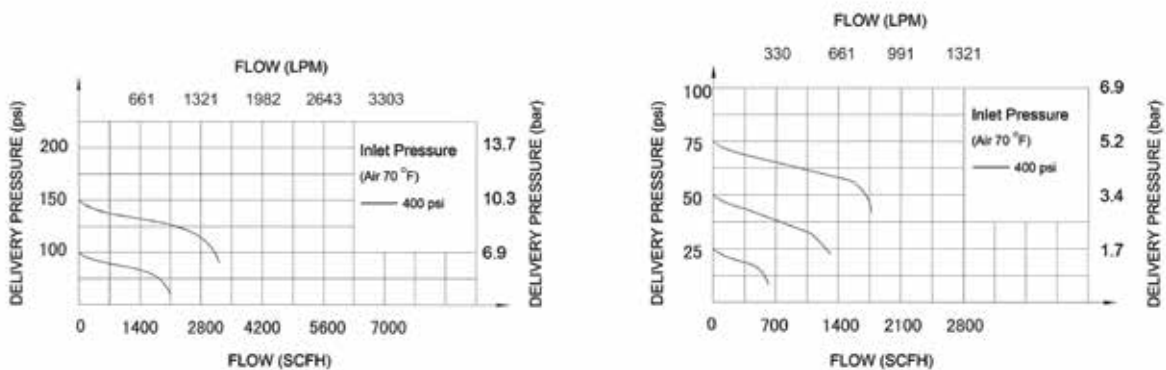

Ordering Information

EX: P35	1	1	S	N -	F	H	P		- N2
Series	Valve Assembly	Inlet Connection	Valve Body	Regulator Seat*	Inlet Pressure	Outlet Pressure	Gauge	Options	Gas Options
• P35	1: Inlet / outlet / vent 2: Inlet / vent 3: Inlet / outlet 4: Inlet only	1: 1/4" Genlok (Vertical) 2: 1/4" FSR (Vertical) 3: 1/2" FSR (Straight) 5: 1/4" NPT (Vertical) 6: 1/4" FNPT (Vertical)	S: Stainless steel	N: Neoprene	F: 500 psi G: 250 psi	L: 25 psi K: 50 psi I: 100 psi H: 150 psi G: 250 psi	P: psi / bar K: psi / kPa W: No Gauge	Blank: Standard C: Electronic Contact Gauge V: Waste gas disposal	Blank: None NH4: Ammonia C2H2: Acetylene

*: Please contact GENTEC for regulator seat

P3200 SERIES

Single-Bank Specialty Gas Manifold Systems

Specialty Gas Equipment



Dimensions

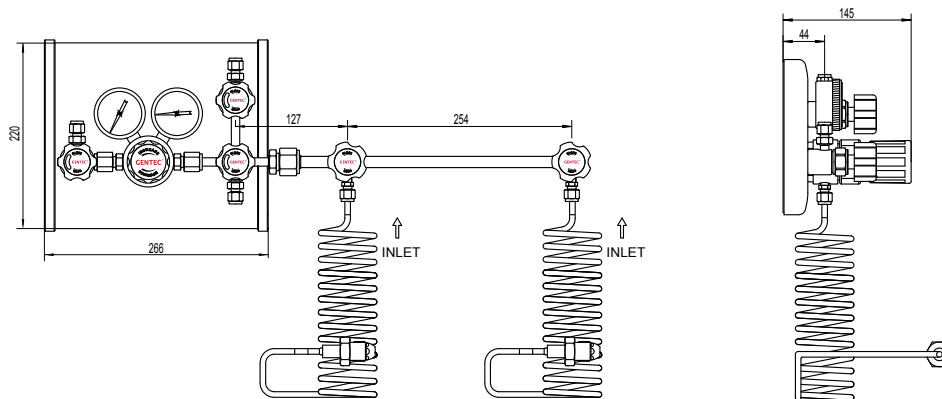

Ordering Information

EX: P32	1	3	S	P -	D	H	P -		2	D -	N2
Series	Valve Assembly	Inlet Connection	Valve Body	Regulator Seat*	Inlet Pressure	Outlet Pressure	Gauge	Options	Header Qty.	Header Connection	Gas Options
• P32	1: Inlet / outlet / vent 2: Inlet / vent 3: Inlet / outlet 4: Inlet only	3: 1/2" FSR (Straight)	S: Stainless steel B: Chrome-plated brass	P: PU T: PTFE K: PCTFE	D: 3000 psi X: 2200 psi F: 500 psi	L: 25 psi K: 50 psi I: 100 psi H: 150 psi G: 250 psi	P: psi / bar K: psi / kPa W: No Gauge	Blank: Standard C: Electronic Contact Gauge V: Waste gas disposal	2	Blank: Without Valve N: With Needle Valve D: With Diaphragm Valve	Blank: None AIR: Air HE: Helium O2: Oxygen H2: Hydrogen CH4: Methane CO2: Carbon Dioxide Ar: Argon N2: Nitrogen

*: Please contact GENTEC for regulator seat



Dimensions

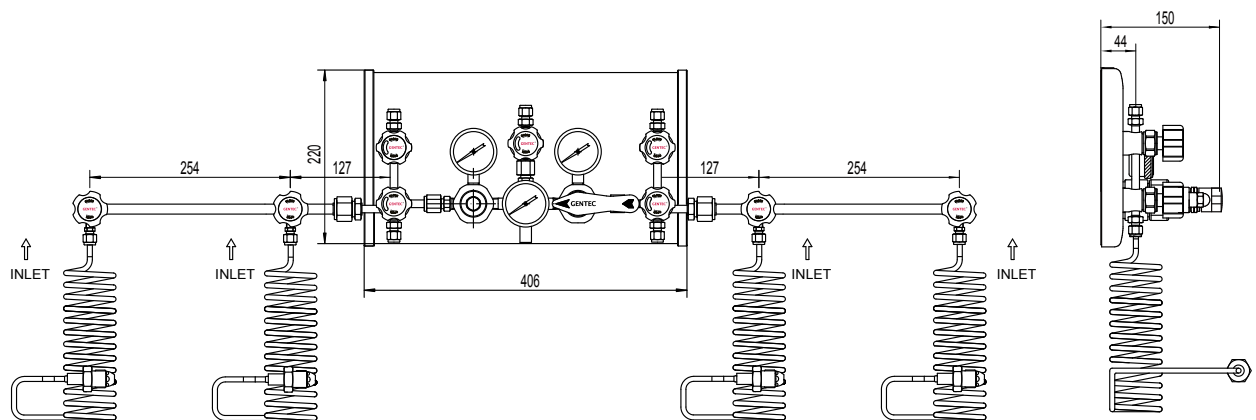

Ordering Information

EX: P33	1	3	S	P -	D	H	P -		2	G -	N2
Series	Valve Assembly	Inlet Connection	Valve Body	Regulator Seat*	Inlet Pressure	Outlet Pressure	Gauge	Options	Header Qty.	Header Connection	Gas Options
<ul style="list-style-type: none"> • P33 • P34 • P35 	1: Inlet / outlet / vent 2: Inlet / vent 3: Inlet / outlet 4: Inlet only	3: 1/2" FSR (Straight)	S: Stainless steel B: Chrome-plated brass	P: PU T: PTFE K: PCTFE	D: 3000 psi X: 2200 psi F: 500 psi	L: 25 psi K: 50 psi I: 100 psi H: 150 psi G: 250 psi	P: psi / bar K: psi / kPa W: No Gauge	Blank: Standard C: Electronic Contact Gauge V: Waste gas disposal	2	Blank: Without Valve N: With Needle Valve D: With Diaphragm Valve	Blank: None AIR: Air HE: Helium O2: Oxygen H2: Hydrogen CH4: Methane CO2: Carbon Dioxide Ar: Argon N2: Nitrogen

*: Please contact GENTEC for regulator seat

P4000 SERIES

Terminal Gas Control Panels

Specialty Gas Equipment

GENTEC® P4000 Series Terminal Gas Control Panel is designed for accurate control of high purity gases in downstream applications where pressure regulation is not required. The P4000 Series come in a variety of configurations ranging from one outlet point to multiple outlet points, as well as one terminal to multiple terminals to meet a wide range of requirements and applications. Please see ordering information for more options.



P4011SL-HG-B12B12



P4021SL-HG-B12B12



P4031SL-HG-B12B12

Product Features

- Designed for terminal gas control
- Easy-to-read 2" stainless steel pressure gauges
- Single panel configuration for easy installation
- Valves are available in three types: ball valves, diaphragm valves, and needle valves

Specifications

- **Maximum outlet pressure:** 25, 50, 100, 150, 250 psi
- **Operating temperature range:** -40 to 165 °F (-40 to 74 °C)
- **Leak rate:** 2×10^{-8} atm.cc/sec He

Materials of Construction

- **Valve body:** Stainless steel
- **Pressure Gauge:** Stainless steel

Dimensions

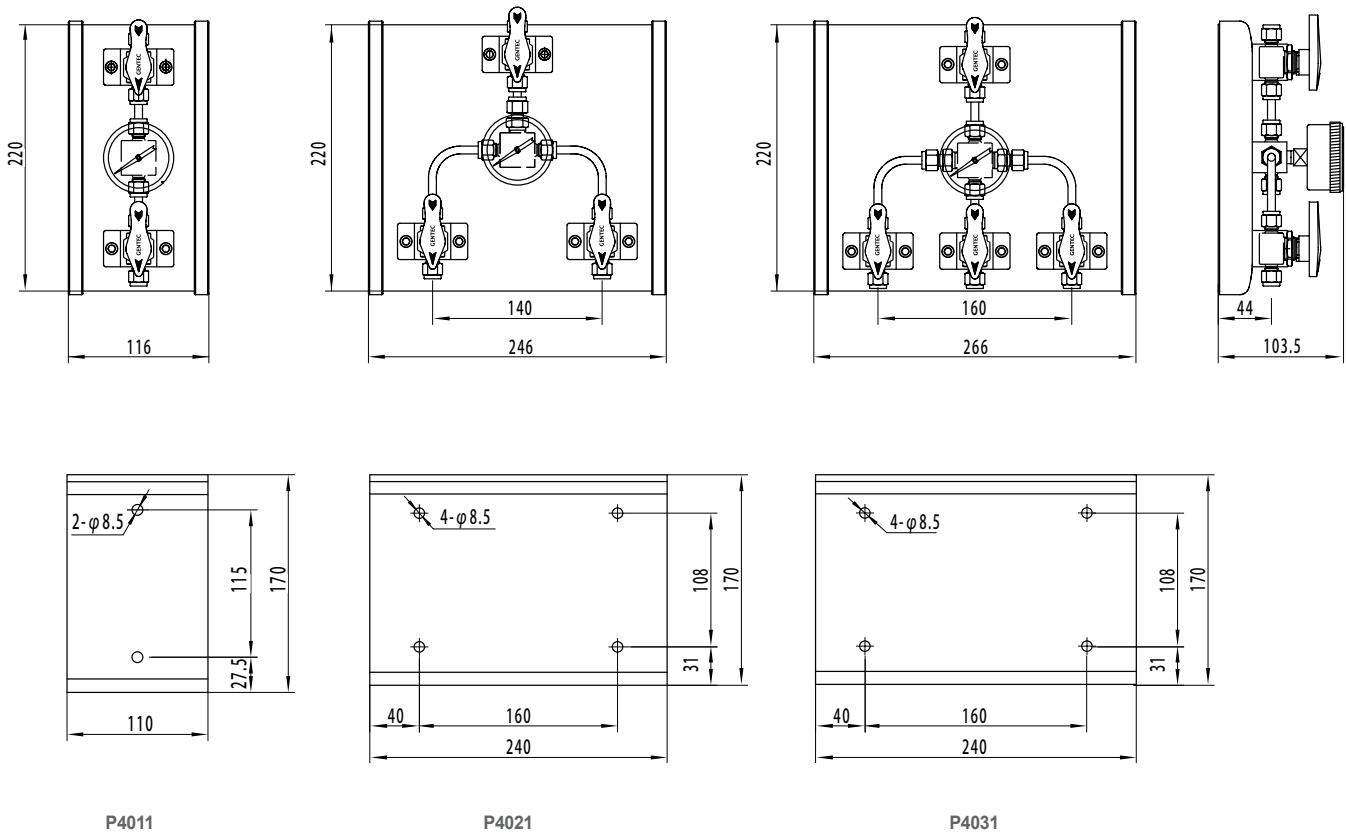

Ordering Information

EX: P40	1	1	SL -	H	P	B	12	W	12 -	AIR
Series	Inlet / Outlet Connection	No. of Terminals	Material	Outlet Pressure	Gauge	Inlet Valve	Inlet Connection	Outlet Valve	Outlet Connection	Gas Options
• P40	1: One inlet / one outlet 2: One inlet / two outlets 3: One inlet / three outlets	1: One 2: Two 3: Three	SL: Stainless steel	L: 25 psi K: 50 psi I: 100 psi H: 150 psi G: 250 psi	P: psi / bar K: psi / kPa	W: Without Valve B: Ball Valve D: Diaphragm Valve	11: 1/8" GENLOK 12: 1/4" GENLOK 13: 3/8" GENLOK 22: 6 mm GENLOK 31: 1/8" NPT 32: 1/4" NPT 61: 1/4" FSR	W: Without Valve B: Ball Valve N: Needle Valve D: Diaphragm Valve	11: 1/8" GENLOK 12: 1/4" GENLOK 13: 3/8" GENLOK 22: 6 mm GENLOK 31: 1/8" NPT 32: 1/4" NPT 61: 1/4" FSR	Blank: None AIR: Air HE: Helium O2: Oxygen H2: Hydrogen CH4: Methane CO2: Carbon Dioxide Ar: Argon N2: Nitrogen

P4100 SERIES

Terminal Gas Control Panels

Specialty Gas Equipment

GENTEC® P4100 Series Terminal Gas Control Panel is designed for accurate control of gases in downstream applications such as laboratory gas distributions, assembly lines, etc. This series of control panels come in a variety of configurations, ranging from one outlet point to multiple outlet points, as well as one terminal to multiple terminals to meet a wide range of requirements and applications. Please see ordering information for more options.



P4111SL-HG-W12B12



P4121SL-HG-W12B12



P4131SL-HG-W12B12

Product Features

- Designed for terminal gas control
- Easy-to-read 2" stainless steel pressure gauges
- Single panel configuration for easy installation
- Valves are available in three types: ball valves, diaphragm valves, and needle valves

Specifications

- **Maximum inlet pressure:** 500 psi
- **Maximum outlet pressure:** 25, 50, 100, 150, 250 psi
- **Operating temperature range:** -40 to 165 °F (-40 to 74 °C)
- **Leak rate:** 2×10^{-8} atm.cc/sec He
- **CV:** 0.14

Materials of Construction

- **Valve body:** Stainless steel
- **Pressure Gauge:** Stainless steel

Dimensions

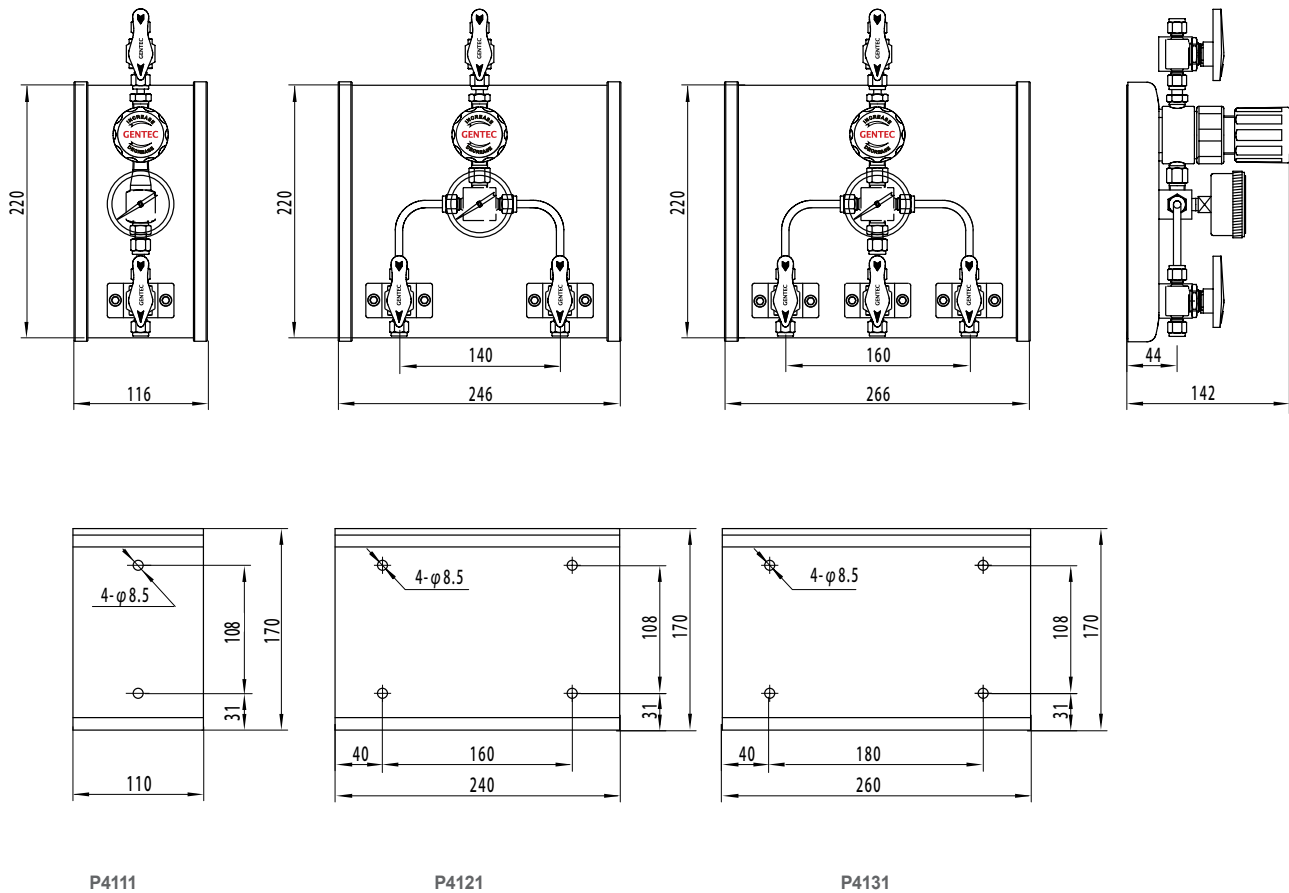

Ordering Information

EX: P41	1	1	SL -	H	P	B	12	W	12 -	AIR
Series	Inlet / Outlet Connection	No. of Terminals	Material	Outlet Pressure	Gauge	Inlet Valve	Inlet Connection	Outlet Valve	Outlet Connection	Gas Options
• P41	1: One inlet / one outlet 2: One inlet / two outlets 3: One inlet / three outlets	1: One 2: Two 3: Three	SL: Stainless steel	L: 25 psi K: 50 psi I: 100 psi H: 150 psi G: 250 psi	P: psi / bar K: psi / kPa	W: Without Valve B: Ball Valve D: Diaphragm Valve	11: 1/8" GENLOK 12: 1/4" GENLOK 13: 3/8" GENLOK 22: 6 mm GENLOK 31: 1/8" NPT 32: 1/4" NPT 61: 1/4" FSR	W: Without Valve B: Ball Valve N: Needle Valve D: Diaphragm Valve	11: 1/8" GENLOK 12: 1/4" GENLOK 13: 3/8" GENLOK 22: 6 mm GENLOK 31: 1/8" NPT 32: 1/4" NPT 61: 1/4" FSR	Blank: None AIR: Air HE: Helium O2: Oxygen H2: Hydrogen CH4: Methane CO2: Carbon Dioxide Ar: Argon N2: Nitrogen

P4200 SERIES

Terminal Gas Control Panels

Specialty Gas Equipment

GENTEC® P4200 Series Terminal Gas Control Panel is designed for accurate control of gases in downstream applications such as laboratory gas distributions, assembly lines, etc. This series of control panels come in a variety of configurations, ranging from one outlet point to multiple outlet points, as well as one terminal to multiple terminals to meet a wide range of requirements and applications. Please see ordering information for more options.



P4211SL-HG-W12B12



P4221SL-HG-W12B12



P4231SL-HG-W12B12

Product Features

- Designed for terminal gas control
- Easy-to-read 2" stainless steel pressure gauges
- Single panel configuration for easy installation
- Valves are available in three types: ball valves, diaphragm valves, and needle valves

Specifications

- **Maximum inlet pressure:** 500 psi
- **Maximum outlet pressure:** 25, 50, 100, 150, 250 psi
- **Operating temperature range:** -40 to 165 °F (-40 to 74 °C)
- **Leak rate:** 2×10^{-8} atm.cc/sec He
- **CV:** 0.14

Materials of Construction

- **Valve body:** Stainless steel
- **Pressure Gauge:** Stainless steel

Dimensions

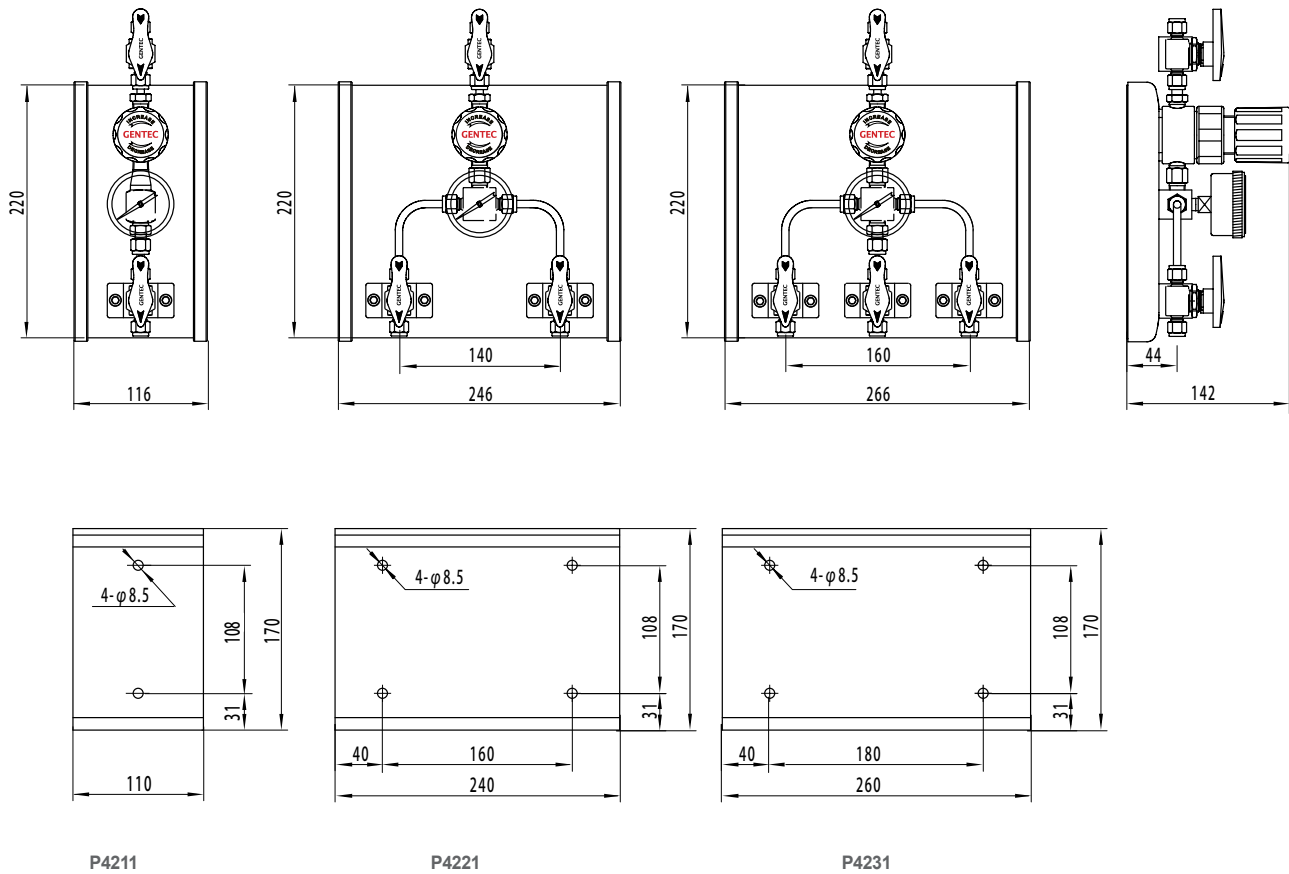

Ordering Information

EX: P42	1	1	SL -	H	P	B	12	W	12 -	AIR
Series	Inlet / Outlet Connection	No. of Terminals	Material	Outlet Pressure	Gauge	Inlet Valve	Inlet Connection	Outlet Valve	Outlet Connection	Gas Options
• P42	1: One inlet / one outlet 2: One inlet / two outlets 3: One inlet / three outlets	1: One 2: Two 3: Three	SL: Stainless steel	L: 25 psi K: 50 psi I: 100 psi H: 150 psi G: 250 psi	P: psi / bar K: psi / kPa	W: Without Valve B: Ball Valve D: Diaphragm Valve	11: 1/8" GENLOK 12: 1/4" GENLOK 13: 3/8" GENLOK 22: 6 mm GENLOK 31: 1/8" NPT 32: 1/4" NPT 61: 1/4" FSR	W: Without Valve B: Ball Valve N: Needle Valve D: Diaphragm Valve	11: 1/8" GENLOK 12: 1/4" GENLOK 13: 3/8" GENLOK 22: 6 mm GENLOK 31: 1/8" NPT 32: 1/4" NPT 61: 1/4" FSR	Blank: None AIR: Air HE: Helium O2: Oxygen H2: Hydrogen CH4: Methane CO2: Carbon Dioxide Ar: Argon N2: Nitrogen

P4400 SERIES

Terminal Gas Control Panels

Specialty Gas Equipment

GENTEC® P4400 Series Terminal Gas Control Panel is designed for accurate control of industrial gases in low flow applications. Regulator, pressure gauge, and ball valve have been forged as one body to minimize the possibility of leaks. This series of control panel comes in one or multiple terminals to meet a wide range of requirements and applications. Please see ordering information for more options.



P4411B-HK-B81W81



P4412B-HK-B81W81



P4413B-HK-B81W81

Product Features

- Designed for terminal gas control
- Easy-to-read 1.5" chrome-plated brass gauges
- Uses BLK 101 Regulator
- Single body minimizes point of leaks and contamination
- Adjustable outlet pressure
- Single panel configuration for easy installation

Specifications

- **Maximum inlet pressure:** 500 psi
- **Maximum outlet pressure:** 25, 50, 100, 150 psi
- **Operating temperature range:** -40 to 165 °F (-40 to 74 °C)
- **Leak rate:** 2×10^{-8} atm.cc/sec He
- **CV:** 0.14

Materials of Construction

- **Regulator and valve body:** Chrome-plated brass
- **Regulator seat:** PTFE
- **Inlet and outlet connection:** 1/8" NPT(F), 1/4" SAE(F)
- **Pressure gauge:** Chrome-plated brass

Dimensions

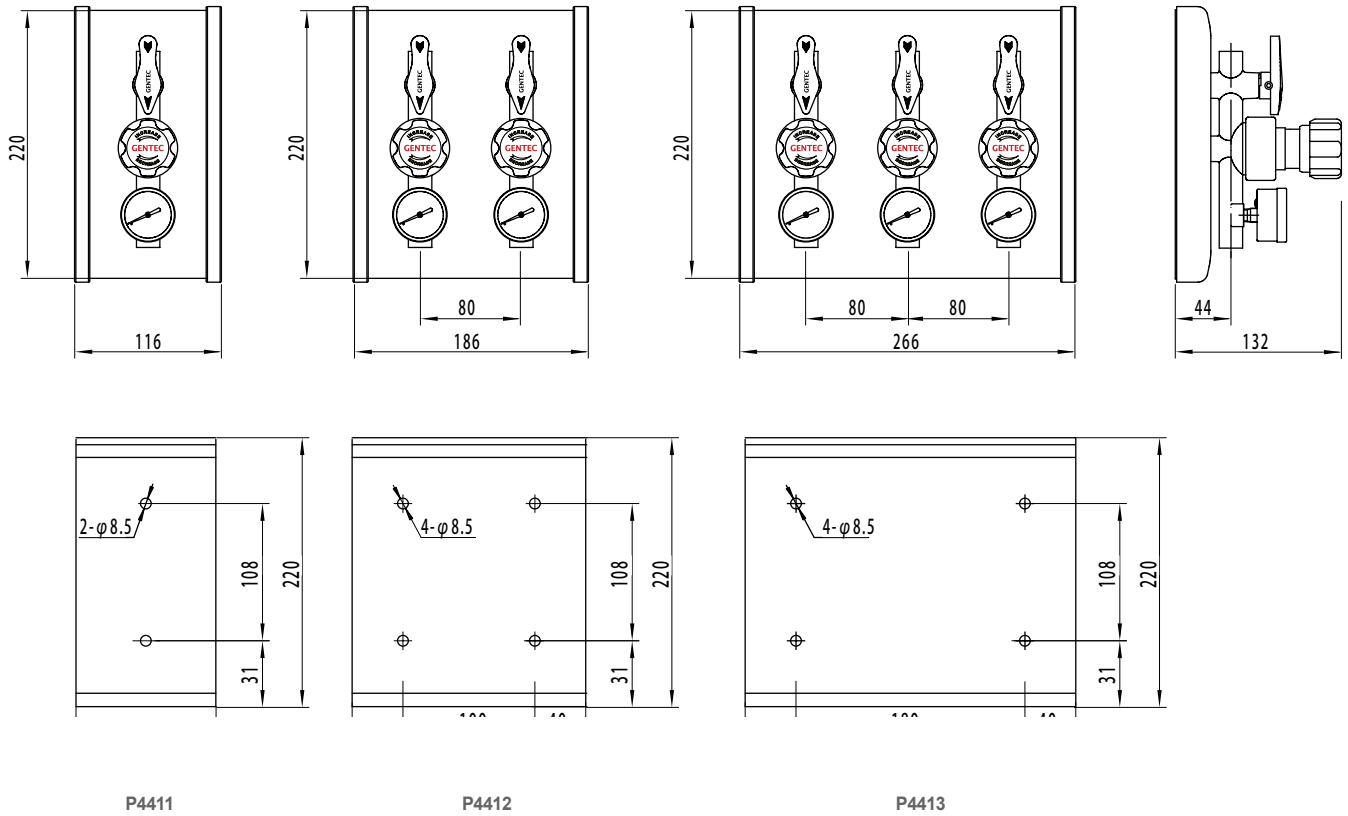

Ordering Information

EX: P44	1	1	B -	H	P	B	31	W	31 -	AIR
Series	Inlet / Outlet Connection	No. of Terminals	Material	Outlet Pressure	Gauge	Inlet Valve	Inlet Connection	Outlet Valve	Outlet Connection	Gas Options
• P44	1: One inlet / one outlet	1: One 2: Two 3: Three	B: Chrome-plated brass	L: 25 psi K: 50 psi I: 100 psi H: 150 psi	P: psi / bar K: psi / kPa	B: Ball Valve	31: 1/8" NPT(F) 61: 1/4" SAE(F)	W: Without Valve	31: 1/8" NPT(F) 61: 1/4" SAE(F)	Blank: None AIR: Air HE: Helium O2: Oxygen H2: Hydrogen CH4: Methane CO2: Carbon Dioxide Ar: Argon N2: Nitrogen

P4500 SERIES

Terminal Gas Control Panels

Specialty Gas Equipment

GENTEC® P4500 Series Terminal Gas Control Panel is designed for accurate control of industrial gases in medium flow applications. Regulator, pressure gauge, and ball valve have been forged as one body to minimize the possibility of leaks. This series of control panel comes in one or multiple terminals to meet a wide range of requirements and applications. Please see ordering information for more options.



P4511B-HK-B83W83

P4521B-HK-B83W83

P4531B-HK-B83W83

Product Features

- Designed for terminal gas control
- Easy-to-read 1.5" chrome-plated brass gauges
- Uses BLK 102 Regulator
- Single body minimizes point of leaks and contamination
- Adjustable outlet pressure
- Single panel configuration for easy installation

Specifications

- **Maximum inlet pressure:** 500 psi
- **Maximum outlet pressure:** 25, 50, 100, 150 psi
- **Operating temperature range:** -40 to 165 °F (-40 to 74 °C)
- **Leak rate:** 2×10^{-8} atm.cc/sec He
- **CV:** 1.1

Materials of Construction

- **Regulator and valve body:** Chrome-plated brass
- **Regulator seat:** PCTFE
- **Inlet and outlet connection:** 3/8" NPT(F), 1/2" SAE (F)
- **Pressure gauge:** Chrome-plated brass

Dimensions

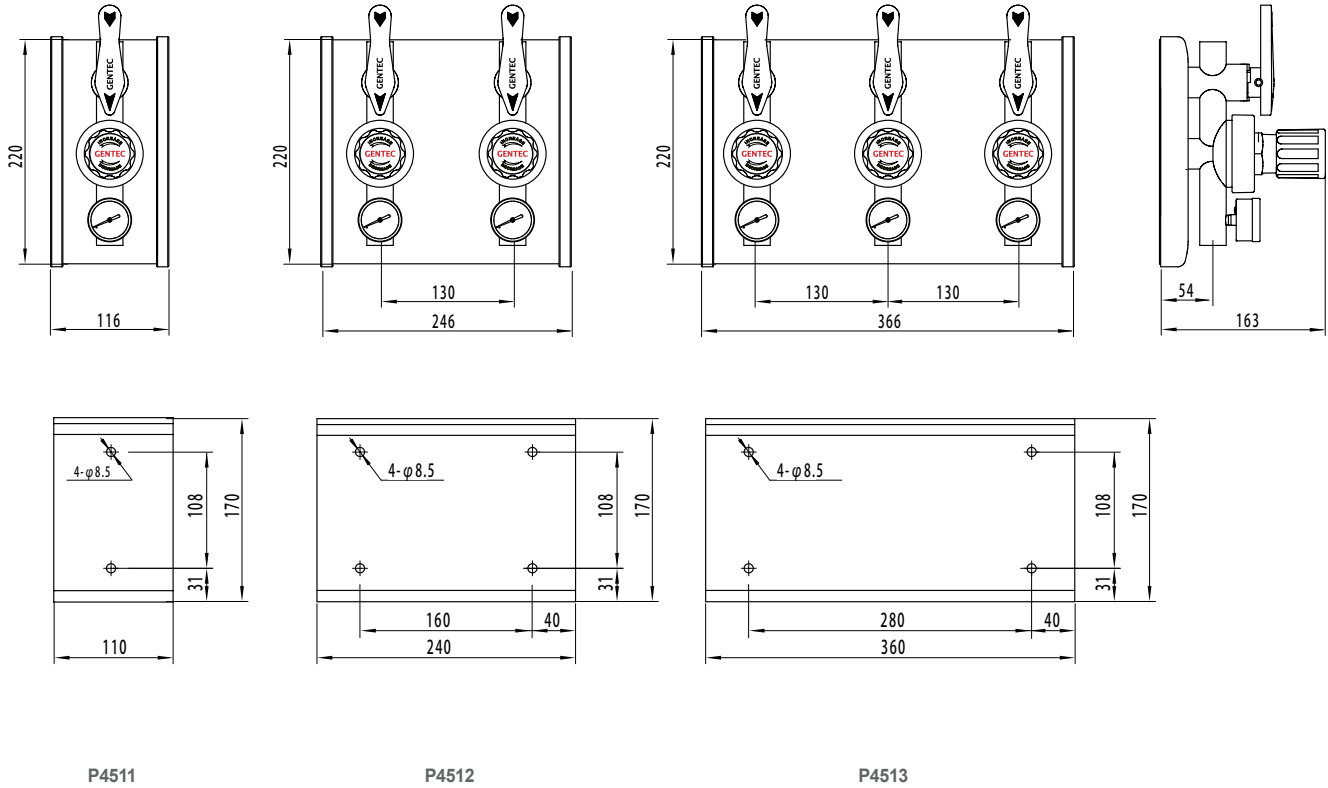

Ordering Information

EX: P45	1	1	B -	H	P -	B	31	W	31 -	AIR
Series	Inlet / Outlet Connection	No. of Terminals	Material	Outlet Pressure	Gauge	Inlet Valve	Inlet Connection	Outlet Valve	Outlet Connection	Gas Options
• P45	1: One inlet / one outlet	1: One 2: Two 3: Three	B: Chrome-plated brass	L: 25 psi K: 50 psi I: 100 psi H: 150 psi	P: psi / bar K: psi / kPa	B: Ball Valve	33: 3/8" NPT(F) 63: 1/2" SAE(F)	W: Without Valve	33: 1/8" NPT 63: 1/4" FSR	Blank: None AIR: Air HE: Helium O2: Oxygen H2: Hydrogen CH4: Methane CO2: Carbon Dioxide Ar: Argon N2: Nitrogen

BS3100 SERIES

Generator Back-up Control Panels

Specialty Gas Equipment

GENTEC® BS3100 Series Generator Back-up Control Panel is a hybrid control system, with the gas generator as the primary source of gas supply and the cylinder as the reserve. The automatic changeover provides a continuous gas supply without interrupting the system during generator maintenance. When the pressure of the generator drops below a preset value, the cylinder will begin to supply gas to the system. The line regulator executes a second stage pressure reduction, providing a consistent outlet pressure and flow. This series is available in both stainless steel and brass.

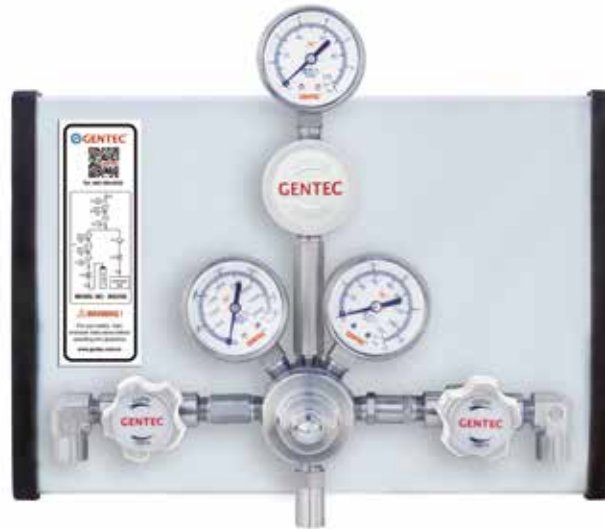

BS3100SL-45-DKP-00

Product Features

- Hybrid dual-bank gas supply and automatic changeover
- Dual-stage pressure reduction to minimizes pressure and flow fluctuation
- Inlet valves allow the user to isolate either source of gas supply for maintenance
- The integrated check valve ensures system safety

Specifications

- **Maximum Generator Inlet Pressure:** 380 psi
- **Maximum Cylinder Inlet Pressure:** 3000 psi
- **Outlet Pressure Range:** 0 ~ 45 psi
- **Maximum Flow:** 60 SLPM
- **Operating temperature range:** -40 to 165 °F (-40 to 74 °C)
- **Leak rate:** 2×10^{-8} atm.cc/sec He
- **Changeover Pressure:** as selected by customer(s)

Materials of Construction

- **Regulator and valve body:** Stainless steel
- **Regulator inlet/outlet port:** 1/4" NPT (F)
- **Cylinder inlet connection:** CGA
- **Inlet valve body:** Stainless steel
- **Check valve body:** Stainless steel

Dimensions

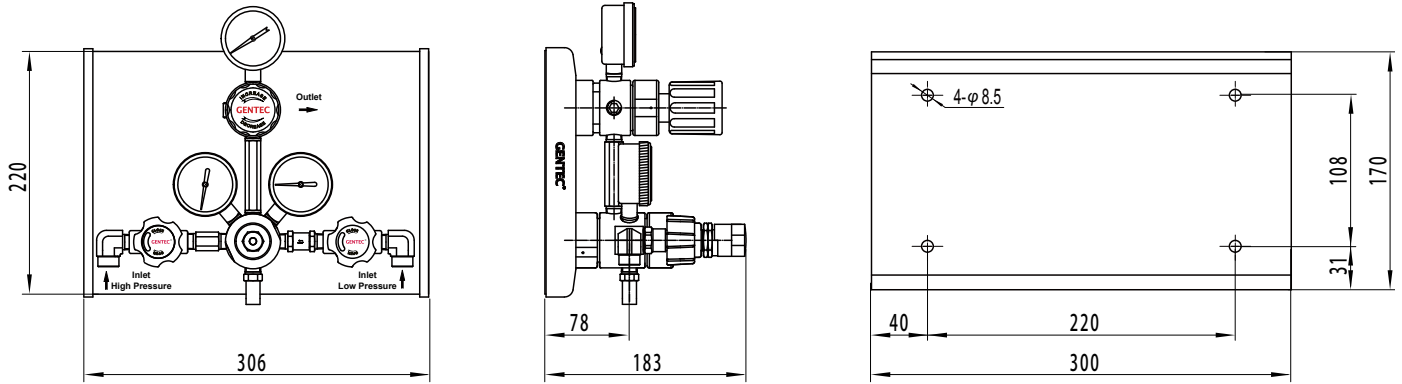

Flow Date

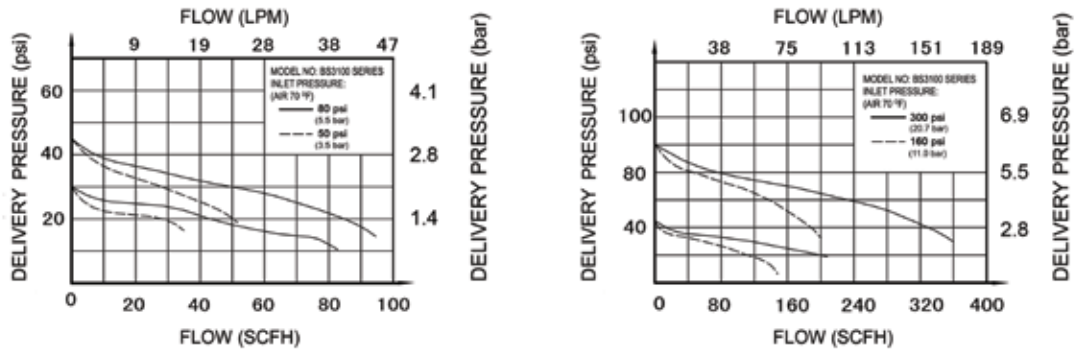

Ordering Information

EX: BS31	0	0	SL -	45	D	K	P	C -	C330 -	AIR
Series	Primary Supply Max. Pressure	Inlet & Outlet Connection	Material	Max. Outlet Pressure	Backup Cylinders Pressure	Preset Pressure	Gauge	Options	Back-up Cylinder Inlet Connection	Gas Options
• BS31	0: 85 psi 1: 180 psi 3: 380 psi	0: No vent valves 1: Vent valves	SL: Stainless steel	45: 45 psi	D: 3000 psi X: 2200 psi F: 500 psi	K: 50 psi I: 100 psi H: 150 psi	P: psi / bar K: psi / kPa	Blank: Standard C: Electronic Contact Gauge	00: 1/4"NPT(F) C330: CGA330 C350: CGA350 52: G5/8'-RH 64: W21.8-LH	Blank: None AIR: Air HE: Helium O2: Oxygen H2: Hydrogen CH4: Methane CO2: Carbon Dioxide Ar: Argon N2: Nitrogen

P2400 SERIES

Semi-Automatic Control Panels

Specialty Gas Equipment

GENTEC® P2400 Series Specialty Gas Control Panel is a dual bank semi-automatic changeover system, providing a continuous supply without interrupting the system during cylinder(s) replacement. P2400 Series is designed with dual pressure reduction to provide steady outlet pressure and is applicable for purity gas usage in research laboratories, clean rooms and gas analyzing.

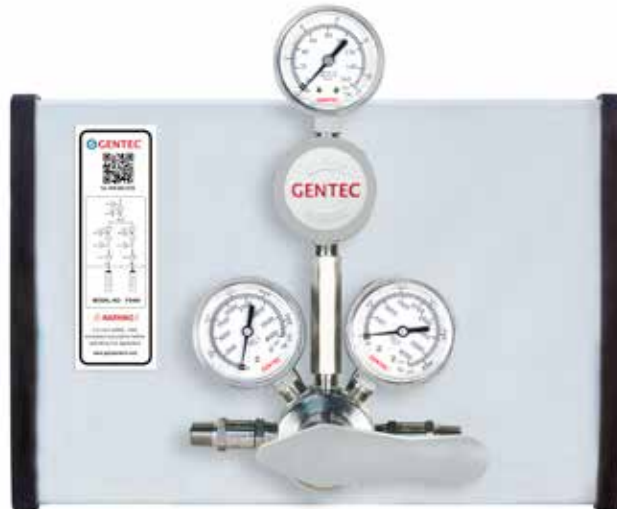

Product Features

- Switchover regulator with relief valve
- Regulator and pipe all through pressure and leakage test
- Easy-to-read 2" stainless steel pressure gauges or chrome-plated brass gauges

Specifications

- **Maximum inlet pressure:** 3000, 2200 psi
- **Maximum outlet pressure:** 25, 50, 100, 150 psi
- **Operating temperature range:** -40 to 165 °F (-40 to 74 °C)
- **Leak rate:** 2×10^{-8} atm.cc/sec He
- **CV:** 0.06

Materials of Construction

- **Regulator body:** Stainless steel
- **Regulator seat:** PU
- **Regulator inlet port:** 1/4" NPT (F)
- **Regulator outlet port:** 1/4" GENLOK

Dimensions

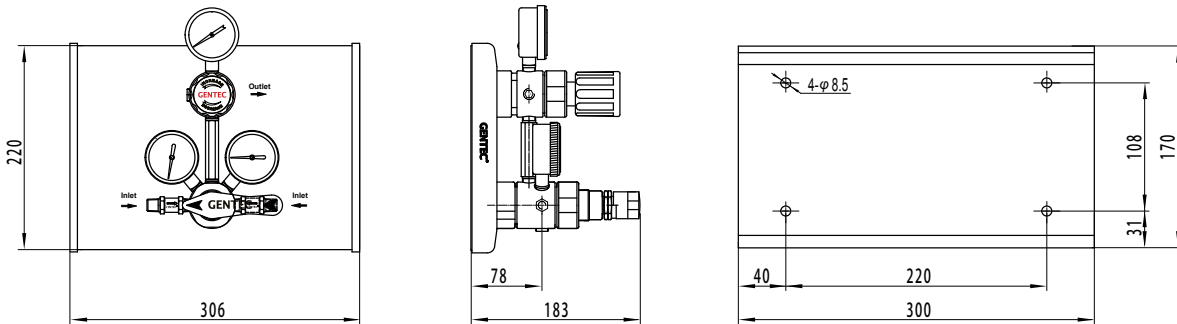

Flow Date

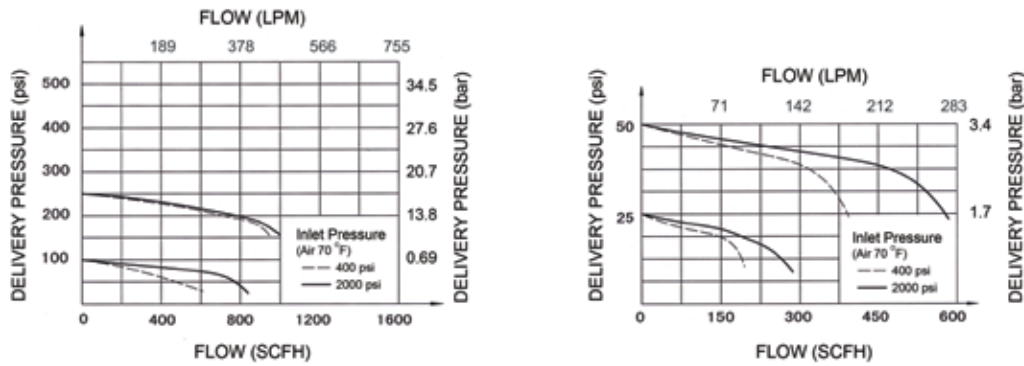

Ordering Information

EX: P2400 Series	S Body	P - Regulator Seat Material	D Inlet Pressure	H Outlet Pressure	P Gauge	Options	- AIR Gas Options
• P2400	S: Stainless steel	P: PU	D: 3000 psi X: 2200 psi	L: 25 psi K: 50 psi I: 100 psi H: 150 psi	P: psi / bar K: psi / kPa	Blank: Standard C: Electronic Contact Gauge	Blank: None AIR: Air HE: Helium O2: Oxygen H2: Hydrogen CH4: Methane CO2: Carbon Dioxide Ar: Argon N2: Nitrogen

GENTEC® SL2500 Series switchover system is designed with Gentec's R21SL Series pressure regulators to provide an uninterrupted supply of gas from two high pressure banks. The system automatically switches from the primary bank to the reserve bank without flow interruptions. An optional audible and visual alarm is available to power the indicator lights for the system.



Product Features

- Weather proof enclosure
- R21SL Series Regulator
- Metal-to-Metal diaphragm of Regulator
- Switch knob with priority bank indicator
- Built-in relief valve
- 3 ft flex pigtail with integral check valve
- Optional Audible and Visual Alarm
- Wall mounts

Specifications

- **Maximum inlet pressure:** 3000 psi
- **Operating temperature range:** -40 to 140 °F (-40 to 60 °C)
- **Leak rate:** 2×10^{-9} atm.cc/sec He
- **CV:** 0.06

Materials of Construction

- **Regulator body:** Stainless steel
- **Regulator Diaphragm:** Stainless steel
- **Bonnet:** 304 Stainless steel
- **Seat:** PCTFE

Dimensions

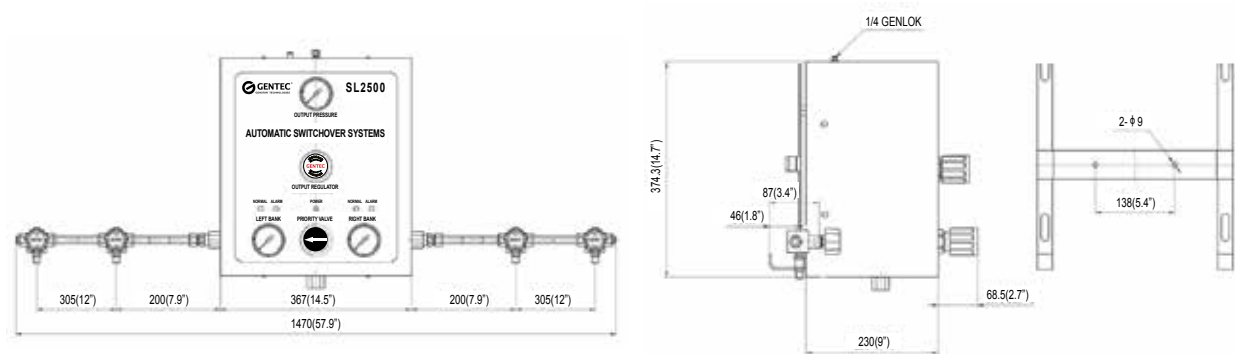

Flow Date

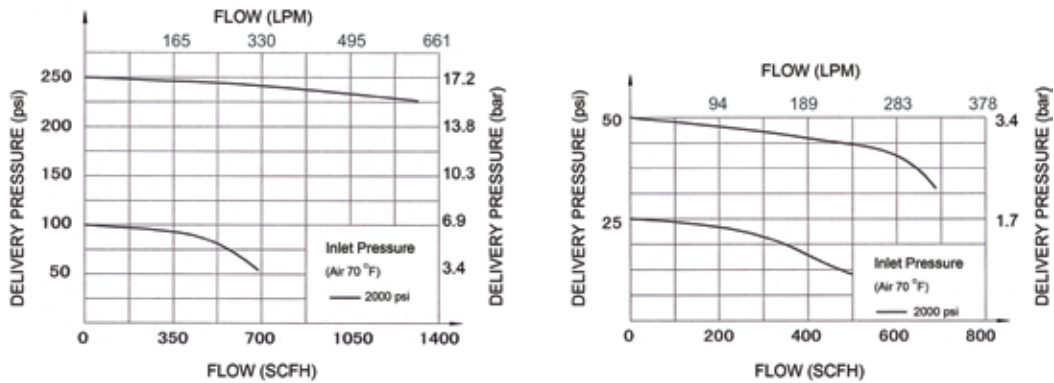

Ordering Information

EX: SL2500 Series	A - Spacing & Layout	100 - Max. Outlet Pressure	Outlet Connection	2L - Left Stations	2R - Right Stations	CGA330 - Inlet Connection	A - Pigtail	1 Options
• SL2500	A: 12" standard B: Custom made*	50: 50 psi 100: 100 psi 250: 250 psi	N: Needle Valve D: Diaphragm Valve No Options: Blank	1 2 3 4 5 n** Blank for Box Only	1 2 3 4 5 n** Blank for Box Only	C330: CGA330 C350: CGA350 C510: CGA510 C540: CGA540 C580: CGA580 C660: CGA660 For other connections, please contact Gentec	A: FSR* ¹ B: NPT* ² C: Tube* ³	1: Alarm 2: Explosion Proof Alarm 3: Flashback arrestors 4: Filter No options: Blank Can choose multiple options

* For different layout design, please contact Gentec

** : specify number of designed stations

***: 7.9" standard spacer between Control Box and Header

*1 A: stainless steel coil tubing, FSR outlet connection, with check valve

*2 B: stainless steel pigtail, NPT outlet connection, with check valve

*3 C: stainless steel pigtail, Tube outlet connection, with check valve

ACCESSORIES

Regulator Protocol Station & Panel Mount

Specialty Gas Equipment

Regulator Protocol Station



Note: Gas Regulators not included with Protocol Station*.

- Designed to provide easy, safe, and fast cylinder exchanges by eliminating the direct connection between the gas regulator and cylinder
- Bracket mount fits both single and dual-stage regulators
- Station blocks are available in chrome-plated brass and 316L stainless steel
- Pigtails are equipped with anti-whip/anti-kink stainless steel arm or casing

Panel Mount

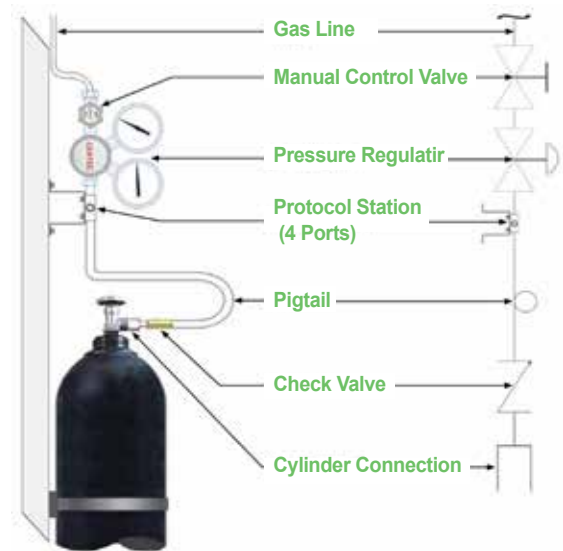
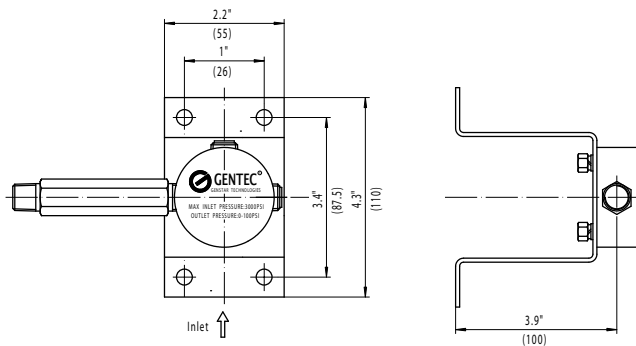

Ordering Information

Series	Bracket Style	Inlet Pressure Range	Inlet Connections (on pigtail)	Outlet Connection (to regulator)	Check Valve	Pigtails (36")
PSSL: 316L PSB: Brass	W: Wall-Mount	D: 3000 psi	01: 1/4"NPT(M) 22: CGA320 23: CGA330 24: CGA350 Other Connections are available	01: 1/4"NPT(M)	CV: With Check Valve Leave blank for no check valves	S: 316L T: Teflon

Header Bars



GSML-210D-FNT4-VSF8



GSMR-210D-FNT4-TF8



GSML-210D-FNT4-TF8

Product Features

- Modular design for easy installation and future expansion
- Outlet connections are available in both Genlok tube fitting and FSR fittings
- Maximum inlet pressure of 3000 psi
- 100% tested to ensure there are no leaks

Materials

- Pipe: OD 1/2", 316L seamless stainless steel tubing (BA grade)
- Connector: 316
- Maximum inlet pressure of 3000 psi
- Diaphragm valve: 316L diaphragm, PCTFE seat, 316L body

Dimensions

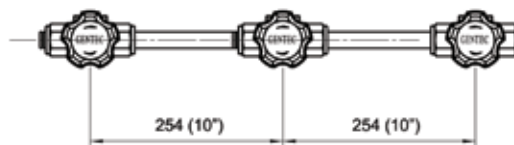

Ordering Information

Series	Structure	Stations	Stations Spacing	Valve Configuration	Inlet Connection	Outlet Connection	Spacer
GSM	R: Right	2 / 3 / 5	05: 5" (127 mm)	W: None	FNT4: 1/4"NPT(F)	VSF8: 1/2"FSR(F) Orbital welded	Blank: 5" (standard)
	L: Left		10: 10" (254 mm) (standard)	N: Needle valve D: Diaphragm valve	NT4: 1/4"NPT(M) VM4: 1/4"FSR(M)	(standard) TF8: 1/2"GENLOK Tube Fittings	
			13: 13" (330 mm)				12: 12"

ACCESSORIES

Purge Tools

Purge Tools

- Purge assembly is highly recommended when a toxic, corrosive, flammable or ultra high purity gas is used in a system.
- Purge assembly enables users to purge systems of contamination.



SL-P101

- Straight purge connection
- For connection to regulator's high pressure inlet
- For regulators and downstream devices
- Purge gases delivered from regulator's downstream
- Suitable for circular purging



SL-P102

- "T"-design purge connection
- For connection between regulator and cylinder
- Purge of whole gas system
- Purge gases delivered from regulator's downstream
- Suitable for circular purging



SL-P103

- Cross design purge connection
- For connection between regulator and cylinder
- Purge of whole gas system, diaphragm valve controls purging for cylinder valve
- Purge gases relieved from purged port of regulator's downstream

Series	Inlet Connections	Outlet Connections
SL-P101	00: 1/4" NPT(F)	00: 1/4" NPT(F)
SL-P102	01: 1/4" NPT(M)	01: 1/4" NPT(M)
SL-P103	C330: CGA330 C350: CGA350 C580: CGA580 C660: CGA660 C590: CGA590 Other connections are available	

Gauges



G20SL
Low Mount (LM)



GR20SL
Back Mount (BM)

Series	Specs.	Wetted	Casing	Connection
G20P (LM)		Brass	Nickel-Plated Steel	1/4" NPT
G20SL (LM)		316L	304	1/4" NPT
GR20SL (BM)		316L	316L	1/4" NPT

2", Dual Scale, Lower Mount				
Model Number		Maxium Scale		Entry
Chrome Plated Brass	Stainless Steel	psi/kPa	psi/bar	
G20P-V30	G20SL-V30	-30in.Hg ~ 30 / 200	-30in.Hg ~ 30 / 2	LM
G20P-V60	G20SL-V60	-30in.Hg ~ 60 / 400	-30in.Hg ~ 60 / 4	LM
G20P-V100	G20SL-V100	-30in.Hg ~ 100 / 700	-30in.Hg ~ 100 / 7	LM
G20P-V150	G20SL-V150	-30in.Hg ~ 100 / 1000	-30in.Hg ~ 100 / 10	LM
G20P-V200	G20SL-V200	-30in.Hg ~ 200 / 1400	-30in.Hg ~ 200 / 14	LM
G20P-V300	G20SL-V300	-30in.Hg ~ 300 / 2000	-30in.Hg ~ 300 / 20	LM
G20P-30	G20SL-30	30 / 200	30 / 2	LM
G20P-60	G20SL-60	60 / 400	60 / 4	LM
G20P-100	G20SL-100	100 / 700	100 / 7	LM
G20P-160	G20SL-160	160 / 1100	160 / 11	LM
G20P-200	G20SL-200	200 / 1400	200 / 14	LM
G20P-300	G20SL-300	300 / 2000	300 / 20	LM
G20P-600	G20SL-600	600 / 4000	600 / 40	LM
G20P-1000	G20SL-1000	1000 / 7000	1000 / 70	LM
G20P-1500	G20SL-1500	1500 / 10000	1500 / 100	LM
G20P-2000	G20SL-2000	2000 / 14000	2000 / 140	LM
G20P-3000	G20SL-3000	3000 / 20000	3000 / 200	LM
G20P-4000	G20SL-4000	4000 / 28000	4000 / 280	LM
G20P-6000	G20SL-6000	6000 / 40000	6000 / 400	LM

2", Dual Scale, Back Mount			
Model Number	Maxium Scale		Entry
Stainless Steel	psi/kPa	psi/bar	
GR20SL-V30	-30in.Hg ~ 30 / 200	-30in.Hg ~ 30 / 2	BM
GR20SL-V60	-30in.Hg ~ 60 / 400	-30in.Hg ~ 60 / 4	BM
GR20SL-V100	-30in.Hg ~ 100 / 700	-30in.Hg ~ 100 / 7	BM
GR20SL-V150	-30in.Hg ~ 100 / 1000	-30in.Hg ~ 100 / 10	BM
GR20SL-V200	-30in.Hg ~ 200 / 1400	-30in.Hg ~ 200 / 14	BM
GR20SL-V300	-30in.Hg ~ 300 / 2000	-30in.Hg ~ 300 / 20	BM
GR20SL-30	30 / 200	30 / 2	BM
GR20SL-60	60 / 400	60 / 4	BM
GR20SL-100	100 / 700	100 / 7	BM
GR20SL-160	160 / 1100	160 / 11	BM
GR20SL-200	200 / 1400	200 / 14	BM
GR20SL-300	300 / 2000	300 / 20	BM
GR20SL-600	600 / 4000	600 / 40	BM
GR20SL-1000	1000 / 7000	1000 / 70	BM
GR20SL-1500	1500 / 10000	1500 / 100	BM
GR20SL-2000	2000 / 14000	2000 / 140	BM
GR20SL-3000	3000 / 20000	3000 / 200	BM
GR20SL-4000	4000 / 28000	4000 / 280	BM
GR20SL-6000	6000 / 40000	6000 / 400	BM

Electronic Contact Gauges



GA20SL
Lower Mount (LM)



GRA20SL
Back Mount (BM)



GE20SL
Lower Mount (LM)



GRE20SL
Back Mount (BM)

- Contact: normally close (no pressure)
- Adjustable between 5 and 80% of the scale range
- Maximum power: 10 watts DC, 12 VAAC
- Maximum switch voltage: 28 V AC/DC
- Wetted area and casing: 316L
- Temperature: -40 to 158°F (-40 to 70°C)
- Connection: 1/4" NPT
- Accuracy: 3-2-3 (2%)
- Potential-free relay

2", Stainless Steel Contact Gauge, PSI/kPa Dual Scale					
Model Number				Maxium Scale	
Twist Cap		Fixed Cap			
Lower Mount	Back Mount	Lower Mount	Back Mount	psi/kPa	psi/bar
GA20SL-100	GRA20SL-100	GE20SL-100	GRE20SL-100	100 / 700	100 / 7
GA20SL-200	GRA20SL-200	GE20SL-200	GRE20SL-200	200 / 1400	200 / 14
GA20SL-300	GRA20SL-300	GE20SL-300	GRE20SL-300	300 / 2000	300 / 20
GA20SL-400	GRA20SL-400	GE20SL-400	GRE20SL-400	400 / 2800	400 / 28
GA20SL-600	GRA20SL-600	GE20SL-600	GRE20SL-600	600 / 4000	600 / 40
GA20SL-1500	GRA20SL-1500	GE20SL-1500	GRE20SL-1500	1500 / 10000	1500 / 100
GA20SL-3000	GRA20SL-3000	GE20SL-3000	GRE20SL-3000	3000 / 20000	3000 / 200
GA20SL-4000	GRA20SL-4000	GE20SL-4000	GRE20SL-4000	4000 / 28000	4000 / 280

Note: Please consult factory on VCR/FSR gauges or psi/bar and psi/kPa dual scale ranges not listed.

ACCESSORIES

Needle Valves, Relief Valves & Diaphragm Valves

Specialty Gas Equipment

Needle Valves



- Designed for use with regulator
- Easy control of outlet flow

Series	Material	Max Working Pressure	Inlet / Outlet Connection
207CP	Nickel-Plated Brass	500 psi	1/4" NPT(M) x 1/4" NPT(M)
SS-NV12-NT4	316	5000 psi	1/4" NPT(M) x 1/4" NPT(M)
SS-NV12-NT4-TF4	316	5000 psi	1/4" NPT(M) x 1/4" GENLOK

Relief Valves



- Designed for use with regulator
- Relief pressure adjustable

Series	Material	Pressure Range	Inlet / Outlet Connection
RV11	SS: 316 B: Nickel-Plated Brass	20: 10-20 psi	1/4" NPT(M) x 1/4" NPT(F)
		100: 20-100 psi	1/4" NPT(M) x 1/4" NPT(F)
		250: 100-250 psi	1/4" NPT(M) x 1/4" NPT(F)
		500: 250-500 psi	1/4" NPT(M) x 1/4" NPT(F)
		750: 500-750 psi	1/4" NPT(M) x 1/4" NPT(F)

Diaphragm Valves



- Designed for regulator outlet port

Series	Cv	Max Working Pressure	Inlet / Outlet Connection
SL-DV92-NT4-FNT4	0.17	3500 psi	1/4" NPT(F) x 1/4" NPT(M)
BP-DV92-NT4-FNT4	0.17	3500 psi	1/4" NPT(F) x 1/4" NPT(M)

Please see "Valves" catalog for more information

Shut-off Valves



- Designed for manifolds

Series	Cv	Max Working Pressure	Inlet / Outlet Connection
SS-DV52-FNT4-NT4	0.73	4500 psi	1/4" NPT(F) x 1/4" NPT(M)
SS-DV52-FNT4-NT4-H	0.73	4500 psi	1/4" NPT(F) x 1/4" NPT(M)

Check Valves



Please contact GENTEC® for additional sizes or cracking pressure available

Model	Inlet Connection	Outlet Connection
SS-CV11-TF2-VI-1	1/8" GENLOK	1/8" GENLOK
SS-CV11-NT2-VI-1	1/8" NPT(M)	1/8" NPT(M)
SS-CV11-FNT2-VI-1	1/8" NPT(F)	1/8" NPT(F)
SS-CV11-TF4-VI-1	1/4" GENLOK	1/4" GENLOK
SS-CV11-NT4-TF4-VI-1	1/4" NPT(M)	1/4" GENLOK
SS-CV11-NT4-VI-1	1/4" NPT(M)	1/4" NPT(M)
SS-CV12-FNT4-VI-1	1/4" NPT(F)	1/4" NPT(F)

Material: 316L | Pressure Rating: 3000 psi | Cracking Pressure: 1 psi | Viton® O-rings standard

Filters



INLINE FILTER

T-TYPE FILTER

Please see "F Series Filters" catalog for more information

Type	Model	Inlet Connection	Outlet Connection
Inline Type	SS-F4-FNT2	1/8" NPT(F)	1/8" NPT(F)
	SS-F4-TF4	1/4" GENLOK	1/4" GENLOK
	SS-F4-NT4	1/4" NPT(M)	1/4" NPT(M)
T-Type	SS-F4T-FNT2	1/8" NPT(F)	1/8" NPT(F)
	SS-F4T-TF4	1/4" GENLOK	1/4" GENLOK
	SS-F4T-NT4	1/4" NPT(M)	1/4" NPT(M)

Material: 316 | Max. Working Pressure: 3000 psi for inline type, 6000 psi for T-type | Washer: 316L | Nominal Pore Size: 0.5-2 microns

Pressure Switches

- Complements gas alarm systems
- Monitors gas pressure
- Designed to provide signal to alarm systems
- Pressure is adjustable



Anti-explosion Model



Standard Model

Model No.	Pressure Range	Max. Inlet Pressure	Connection	Anti-explosion
GHPS-1	4~50 psi (0.28~3.45 bar)	1000 psi (69 bar)	1/8" NPT(M)	NO
GHPS-2	300~600 psi (21.68~41.37 bar)	2500 psi (172 bar)	1/8" NPT(M)	NO
GHPS-3	100~1500 psi (6.89~103 bar)	8000 psi (552 bar)	1/4" NPT(M)	NO
GHPS-4E	2~25 psi (0.14~1.72 bar)	600 psi (42 bar)	1/4" NPT(F)	YES
GHPS-5E	15~75 psi (1.03~5.17 bar)	600 psi (42 bar)	1/4" NPT(F)	YES
GHPS-6E	50~450 psi (3.45~31.03 bar)	2000 psi (138 bar)	1/4" NPT(F)	YES

ACCESSORIES

Gas Pressure Alarms & Flashback Arrestors

Specialty Gas Equipment

Gas Pressure Alarm

- Connect with pressure gauge & pressure switch for monitoring of gas(es)
- LED display 1 to 4 gas status
- Sound alarm
- Mute button
- Connection for distance alarm
- Voltage: 110VAC/ 220VAC



SGPA-2-220

* For explosion-proof model, add "S" to the model number

GUMACSTM Series Digital Alarm Display



- Can be used to monitor pressure, flow rate, temperature, humidity, concentration, and other safety indexes

* LIST 2 Gas, and 3 Gas and 4 gas models.

Flashback Arrestors (Brass)



- Designed for use with low pressure manifold piping
- Preventing flashbacks from low to high pressure piping

Model No.	Gas Service	Working Pressure	Delivery Flow	Inlet Connection	Outlet Connection
FA30PF	Acetylene, propane	22 psi (1.5 bar)	2500 SCFH	3/4"NPT(F)	3/4"NPT(F)
FA30PO	Oxygen	145 psi (10 bar)	5825 SCFH	3/4"NPT(F)	3/4"NPT(F)
FA31PH	Hydrogen	50 psi (3.5 bar)	2120 SCFH	1/4"NPT(F)	1/4"NPT(F)
FA32PH	Hydrogen	50 psi (3.5 bar)	1060 SCFH	G3/8"-LH(F)	G3/8"-LH(F)
FA34P	Hydrogen	50 psi (3.5 bar)	1060 SCFH	1/4"NPT(F)	1/4"NPT(F)
FA40HPF	Hydrogen	435 psi (130 bar)	2120 SCFH	G3/8"-LH(F)	G3/8"-LH(F)

Flashback Arrestors (Stainless Steel)



Model No.	Gas Service	Working Pressure	Delivery Flow	Inlet Connection	Outlet Connection
FA33SP	Hydrogen	50 psi (3.5 bar)	2120 SCFH	1/4" NPT(F)	1/4" NPT(F)
	Acetylene	22 psi (1.5 bar)	350 SCFH	1/4" NPT(F)	1/4" NPT(F)
	propane	50 psi (3.5 bar)	425 SCFH	1/4" NPT(F)	1/4" NPT(F)
HFA43SP	Hydrogen	145 psi (10 bar)	3530 SCFH	3/8" NPT(F)	3/8" NPT(F)
	Methane	175 psi (12 bar)	1550 SCFH	3/8" NPT(F)	3/8" NPT(F)
	Acetylene	130 psi (9 bar)	1060 SCFH	3/8" NPT(F)	3/8" NPT(F)
	propane	115 psi (8 bar)	780 SCFH	3/8" NPT(F)	3/8" NPT(F)

Vacuum Generator



- 316L stainless steel construction
- Cleaned, welded assembled, tested and packaged in Class 10 clean room
- Internal surface finish 0.4 um
- 660 mmHg (100 Torr) vacuum generated with a minimum source nitrogen pressure of 75 psi
- Helium leak tested
- Used in gas delivery systems to assist in purging piping systems

EX: SL - Material	VG22 - Serial No.	VM4 - N2 Inlet	VM8 - Vent Connection	VSM4 Vacuum Connections
SL: 316L	VG22	VM4	VM8	VM4 VSM4 VSF4

Connections
VM4: 1/4" face seal male
VM8: 1/2" face seal male
VSM4: 1/4" face seal swivel male
VSF4: 1/4" face seal swivel female

Tube Fittings



SS-MC-TF4-NT4



SS-UE-TF4



SS-FC-TF4-FNT4



R952-5503

Series	Material	Inlet/Outlet Connection
R195-51P	Nickel-Plated Brass	1/4" NPT(M) x 1/4" NPT(M), Connection
R952-5503	316 Stainless Steel	1/4" NPT(M) x 1/4" NPT(M), Connection
SS-MC-TF4-NT4	316 Stainless Steel	1/4" NPT(M) x 1/4" Genlok, Connection
SS-MC-TF6-NT4	316 Stainless Steel	3/8" NPT(M) x 1/4" Genlok, Connection
SS-MC-TF8-NT4	316 Stainless Steel	1/2" NPT(M) x 1/4" Genlok, Connection
SS-MC-TF8-NT8	316 Stainless Steel	1/2" NPT(M) x 1/2" Genlok, Connection
SS-MC-TF12-NT12	316 Stainless Steel	1/2" NPT(M) x 3/4" Genlok, Connection
SS-FC-TF2-FNT4	316 Stainless Steel	1/4" NPT(F) x 1/8" Genlok, Connection
SS-FC-TF4-FNT4	316 Stainless Steel	1/4" NPT(F) x 1/4" Genlok, Connection
SS-FC-TF6-FNT4	316 Stainless Steel	1/4" NPT(F) x 3/8" Genlok, Connection
SS-FC-TF8-FNT4	316 Stainless Steel	1/4" NPT(F) x 1/2" Genlok, Connection
R155-64JP	Nickel-Plated Brass	1/2" NPT(M) x 3/8" NPT(F), Straight
R155-64KP	Nickel-Plated Brass	1/2" NPT(M) x 3/8" NPT(M), Straight
R155-64EP	Nickel-Plated Brass	1/2" NPT(M) x 1/2" NPT(M), Straight
R982-5502	316 Stainless Steel	1/2" NPT(M) x 3/8" NPT(F), Straight
R982-5507	316 Stainless Steel	1/2" NPT(M) x 3/8" NPT(M), Straight
R982-5506	316 Stainless Steel	1/2" NPT(M) x 1/2" NPT(M), Straight
SS-UE-TF4	316 Stainless Steel	1/4" Genlok x 1/4" Genlok, Elbow
SS-UE-TF8	316 Stainless Steel	1/2" Genlok x 1/2" Genlok, Elbow

Please see "Tube Fittings" catalog for more information

Cylinder Connection Table



• Nuts and nipples are designed for regulator inlet connections.

BS341	Model No.	Material	Nut	Nipple	Washer
NO. 2	SS-BS341#2-NT4	Stainless Steel	G5/8-14	3" Length	
	BP-BS341#2-NT4	Brass / Nickel-Plated	(Left Hand)	(1/4" NPT)	
NO. 3	SS-BS341-3	Stainless Steel	G5/8-14	3" Length	
	BP-BS341-3	Brass / Nickel-Plated	(Right Hand)	(1/4" NPT)	
NO. 4	SS-BS341-4	Stainless Steel	G5/8-14	3" Length	
	BP-BS341-4	Brass / Nickel-Plated	(Left Hand)	(1/4" NPT)	
DIN477	Model No.	Material	Nut	Nipple	Washer
NO. 5	SS-DIN477-5	Stainless Steel	1"-11	2-1/2" Length	Nylon
	BP-DIN477-5	Brass / Nickel-Plated	(Left Hand)	(1/4" NPT)	
NO. 6	SS-DIN477-6	Stainless Steel	W21.8-14	2.35" Length	Nylon
	BP-DIN477-6	Brass / Nickel-Plated	(Right Hand)	(1/4" NPT)	
NO. 8	SS-DIN477-8	Stainless Steel	1"-11	2.35" Length	PTFE
	BP-DIN477-8	Brass / Nickel-Plated	(Right Hand)	(1/4" NPT)	
NO. 9	SS-DIN477-9	Stainless Steel	G3/4-14	2.35" Length	Nylon
	BP-DIN477-9	Brass / Nickel-Plated	(Right Hand)	(1/4" NPT)	
CGA	Model No.	Material	Nut	Nipple	Washer
330	SS-CGA330	Stainless Steel	0.830-14NGO	2" Length	Nylon
	BP-CGA330	Brass / Nickel-Plated	(Left Hand)	(1/4" NPT)	
350	SS-CGA350	Stainless Steel	0.830-14NGO	2-1/2" Length	Nylon
	BP-CGA350	Brass / Nickel-Plated	(Left Hand)	(1/4" NPT)	
580	SS-CGA580	Stainless Steel	0.960-14NGO	3" Length	
	BP-CGA580	Brass / Nickel-Plated	(Right Hand)	(1/4" NPT)	
590	SS-CGA590	Stainless Steel	0.960-14NGO	3" Length	Nylon
	BP-CGA590	Brass / Nickel-Plated	(Left Hand)	(1/4" NPT)	
660	SS-CGA660	Stainless Steel	1.035-14NGO	2" Length	PTFE
	BP-CGA660	Brass / Nickel-Plated	(Right Hand)	(1/4" NPT)	

* Note: More connections available upon request.

Wall-Mount Brackets



GMB-R1



GMB-R6

Model Number	Inlet / Outlet Connection
GMB-R1	R21, R22 Bracket
GMB-R2	R31 Bracket
GMB-R6	R11, R12, R14, R15, R21, R22, R44 Bracket

Pigtails

- Designed for use between cylinder and piping system
- Max. Pressure: GFPT and GFPS Series: 3000 psi (206 bar)
GRPS Series: 4500 psi (310 bar)
- Temp. Range: GFPS and GRPS Series: -325 to 850°F (-200 to 454°F)
GFPT: -65 to 450°F (-53 to 230°C)
- Oxygen Service: Meets CGA G4.1 Specifications for cleanliness



GRPS

GRPS - Series	C330 - Inlet Connections	CV - Options	00 Outlet Connections
GRPS: Stainless Steel Rigid Pigtail	00: 1/4" NPT(F) C330: CGA330 C350: CGA350 C510: CGA510 C540: CGA540 C580: CGA580 C660: CGA660	Blank: None CV: with Check Valve FA: with Flashback Arrestor	00: 1/4" NPT(F) VSF4: 1/4" Female FSR OD4: 1/4" Tube



GFPT / GFPS

GFPT Series	24 - Length	C330 - Inlet Connections	CV - Options	00 Outlet Connections
GFPT: Stainless Steel Flexible Pigtail with Teflon Insert	24: 24" 36: 36"	00: 1/4" NPT(F) C330: CGA330 C350: CGA350 C510: CGA510 C540: CGA540 C580: CGA580 C660: CGA660	Blank: None CV: with Check Valve FA: with Flashback Arrestor	00: 1/4" NPT(F)
GFPS: Stainless Steel Flexible Pigtail with Stainless Steel Insert				

MATERIAL COMPATIBILITY

A GENTEC® Product Material Compatibility

Specialty Gas Equipment

Gas	Material											
	Aluminum	Brass	Copper	Mone	Stainless Steel	Carbon Steel	Neoprene	PCTFE (Kel-F)	Viton	Polyethyler	PVC	PTFE (Teflon)
Ammonia	●	○	○	●	●	○	●	●	○	○	●	●
Argon	●	●	●	●	●	●	●	●	●	●	●	●
CO ₂	●	●	●	●	●	●	●	●	●	●	●	●
Chlorine	○	○	○	●	●	●	○	●	●	●	○	●
Diborane	●	●	●	●	●	●	○	●	●	○	○	●
Helium	●	●	●	●	●	●	●	●	●	●	●	●
Hydrogen	●	●	●	●	●	●	●	●	●	●	●	●
HCl	○	○	○	●	●	○	●	●	●	●	●	●
H ₂ S	●	○	○	●	●	○	○	●	●	●	●	●
Methane	●	●	●	●	●	●	●	●	●	●	●	●
Nitrogen	●	●	●	●	●	●	●	●	●	●	●	●
N ₂ O	●	●	●	●	●	●	●	●	●	●	●	●
Oxygen	●	●	●	●	●	●	●	●	○	○	○	●
Phosphine	●	○	○	●	●	●	○	●	●	●	●	●
Silane	●	●	●	●	●	●	●	●	●	●	●	●
SO ₂	●	●	●	●	●	●	○	●	○	●	●	●
F ₂ S	●	●	●	●	●	●	●	●	●	●	●	●
Arsine	○	●	○	●	●	●	●	●	●	●	●	●
Boron Trichloride	○	○	●	●	●	●	○	●	●	○	●	●
Boron Trifluoride	●	○	●	●	●	●	○	●	○	○	●	●
Dichlorosilane	○	○	○	●	●	●	○	●	○	○	○	●
Silicon Tetrachloride	○	○	○	●	●	●	○	●	○	○	○	●
Acetylene	●	●	○	●	●	●	●	●	●	●	○	●
Air	●	●	●	●	●	●	●	●	●	●	●	●
Butane	●	●	●	●	●	●	●	●	●	○	●	●
Carbon Monoxide	●	●	●	●	●	●	○	●	●	●	●	●
Cyclopropane	●	●	●	●	●	●	●	●	●	●	●	●
Ethane	●	●	●	●	●	●	●	●	●	●	●	●
Ethylene	●	●	●	●	●	●	●	●	●	○	○	●
Ethylene Oxide	●	●	●	●	●	●	○	●	○	○	○	●
Isobutane	●	●	●	●	●	●	●	●	●	○	●	●
Krypton	●	●	●	●	●	●	●	●	●	●	●	●
Methyl Chloride	○	○	●	●	●	●	●	●	●	●	○	●
Neon	●	●	●	●	●	●	●	●	●	●	●	●
NO	●	○	○	○	●	●	○	●	●	●	●	●
Propane	●	●	●	●	●	●	●	●	●	●	●	●
Xenon	●	●	●	●	●	●	●	●	●	●	●	●

● Recommended ○ Not Recommended ● Recommended only for dry-grades of gas

Gas	BSP	DIN	CGA	UHP CGA	JIS
Acetylene	BS341 No. 2	==	510	==	==
Air	BS341 No. 3	==	346	==	==
Ammonia	BS341 No. 10	DIN6	705	720	22-R
Argon	BS341 No. 3	DIN6	580	718	22-4 or 23-R
Arsine	==	==	350	632	22-L
Boron Trichloride	==	DIN8	660	634	==
Boron Trifluoride	==	DIN8	330	642	22-L
Butane	BS341 No. 4	==	510	==	==
Carbon Dioxide	BS341 No. 8	DIN6	320	716	==
Carbon Monoxide	BS341 No. 4	DIN5	350	724	22-L
Cyclopropane	BS341 No. 4	==	510	==	==
Diborane	==	==	350	632	22-L
Dichlorosilane	==	DIN5	678	636	==
Diethylzinc	==	==	510	726	==
Ethane	==	==	350	==	==
Ethyl Chloride	==	==	510	==	==
Ethylene	==	==	350	==	==
Ethylene Oxide	==	==	510	==	==
Germane	==	==	350 or 660	632	==
R11 (R116) / Halocarbon 11 (116)	==	==	660	716	==
R12 (R13, R23, R115) / Halocarbon 12 (13, 23, 115)	==	DIN6	660	716	==
R14 (Halocarbon 14)	==	DIN6	320 or 580	716	==
Helium	BS341 No. 3	DIN6	580	718	22-R or 23-L
Hydrogen	BS341 No. 2	DIN1	350	724	22-L
Hydrogen Chloride	==	DIN8	330	634	26-R
Hydrogen Fluoride	==	==	660 or 670	638	26-R
Hydrogen Sulfide	==	DIN5	330	722	==
Iso-Butane	==	==	510	==	==
Krypton	==	DIN6	580	718	22-R or 23-R
Methane	BS341 No. 2	==	350	==	==
Methyl Chloride	==	==	660	==	==
Natural Gas	==	==	350	==	==
Neon	==	DIN6	580	718	22-R or 23-R
Nitric Oxide	==	==	660	==	==
Nitrogen	BS341 No. 3	DIN10	580	718	22-R or 23-R
Nitrogen Trifluoride	==	DIN8	330 or 670	640	==
Nitrous Oxide	BS341 No. 13	DIN9	326	712	==
Oxygen	BS341 No. 3	DIN1	540	714	22-R or 23-R
Phosphine	==	==	350	632	==
Propane	BS341 No. 4	==	510	==	==
Silane	==	==	350	632	==
Silicon Tetrachloride	==	==	330	636	==
Silicon Tetrafluoride	==	==	330	642	22-L
Sulfur Hexafluoride	==	DIN6	590	716	26-R
Tungsten Hexafluoride	==	DIN8	670	638	
Xenon	==	DIN6	580	718	22-R

*Chart is for reference only

WARRANTY

A GENTEC® Warranty Information

Specialty Gas Equipment

Any GENTEC® apparatus found to be defective either in material or workmanship during the time set forth below will be replaced by Genstar Technologies Company, Incorporated or its Authorized Distributors, provided that said apparatus was used under normal conditions for the purpose intended.

GENTEC® apparatus damaged or rendered inoperative due to abuse, negligence, misuse, accident or abnormal wear and tear is not covered by this warranty and must be repaired at the sole expense of the equipment owner. GENTEC® apparatus should be serviced facilities only. Service or repair of this apparatus by other than Genstar Technologies Company, Incorporated or designated service facilities may void any warranties and relieve Genstar Technologies Company, Incorporated of any claims for damage and/or liability.

To make a claim under this warranty, Buyer must notify Genstar Technologies Company, Incorporated or its Authorized Distributor of the details of such claim within 30 days of discovering a defect in material or workmanship along with proof of purchase. The Buyer will be responsible for transportation costs and related risks.

Genstar Technologies Company, Incorporated shall not, under any circumstances, be liable for any damages including but not limited to: indirect, incidental, consequential, or special damages, wether such damages result from negligence, breach of warranty or otherwise.

There are no other warranties, expressed or implied, except as stated herein. This warranty gives you specific legal rights, and you may also have other rights which vary from state to state. Genstar Technologies company, Incorporated reserves the right to dicontinue manufacturing of any product or change product materials, design or specifications without notice.

Warranty from the Date of Original Purchase



GENTEC®
High
Purity
Regulators

• 90 days in
corrosive service



Pigtaills



* GENTEC® Industrial Manifold Systems are not included in this catalog.

• Please refer to GENTEC® MANIFOLD SYSTEM catalog (Catalog No. MC 200802)



Gas Control Systems Solutions Overview

- Manifold Systems
- Control Panels
- HP/UHP Regulators
- Pressure Gauges
- Valves & Fittings



Specialty Gas Regulators & Accessories

- General Purpose Forged Brass Regulators
- High Purity Brass Barstock Regulators
- High Purity Stainless Steel Barstock Regulators
- Accessories



Ultra High Purity

- U Series Regulators
- DV Series Valves
- Pressure Gauges
- Face Seal Fittings
- Weld Fittings
- Vacuum Generators



Valves

- Needle Valves
- Ball Valves
- Diaphragm Valves
- Cylinder Valves
- Gauge Valves
- Check Valves



Tube Fittings

- Male Connectors
- Male Elbows
- Male Adapters
- Female Connectors
- Female Elbows
- Unions
- Reducing unions



Cryogenic Gas Equipment

- Cryogenic Relief Valves
- Cryogenic Shut-off Valves
- Cryogenic Regulators
- Check Valves
- Burst-Disc
- LNG Nozzle/Quick Disconnect
- Excess Flow Valves
- Pressure Gauges



F Series Filters

- Inline Filters
- T-type Filters

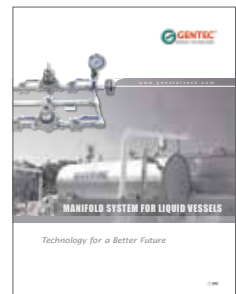

Manifold Systems for Liquid Vessels

Please contact us for any questions about catalogs.

- Requesting Catalogs
- Register an account to view / download pdf catalogs. (Online Register)

To view our full line of Specialty Gas Products please visit us online at www.genstartech.com



GENSTAR TECHNOLOGIES COMPANY INC.
4525 Edison Ave, Chino, CA 91710
Tel: 909.606.6726
Fax: 909.606.6485
www.genstartech.com

