

R51SL SERIES

Corrosion Resistant Low Flow Regulator

Specialty Gas Equipment



▶ R51SLGK-DIP-90-90

GENTEC® R51SL Series Corrosion-Resistant Single-Stage Regulator is Diaphragm-Sensed and especially designed for applications where corrosive and toxic gases are used.

Product Features

- Single-Stage Configuration
- Metal-to-Metal diaphragm to body seal & dual layer sealing ring
- Integrated waste gas disposal connection for additional safety
- Inlet & Outlet Port Size: 1/4" FSR(F)

Materials

- | | |
|---------------|---|
| • Body | 316L (EP) - Stainless Steel, Hastelloy® |
| • Bonnet | 316L - Stainless Steel |
| • Seat | PCTFE |
| • Valve Stem: | C22 Hastelloy® |
| • Diaphragm | C22 Hastelloy® |

Applications

- Semiconductor Industry
- Solar Energy Industry
- Vacuum Plating Equipment
- Spec Gas Equipment

Specifications

- Maximum inlet pressure: 3000 psi (206 bar)
- Maximum outlet pressure: 250 psi (17 bar)
- Safety test pressure: 1.5 x Maximum inlet pressure
- Temperature range: -40 to 165°F (-40 to 74°C)
- Inboard leakage: 2×10^{-8} atm.cc/sec He
- Outboard leakage: 2×10^{-8} atm.cc/sec He
- Maximum Cv: 0.16
- Weight: 3.42 lb (1.55 kg)

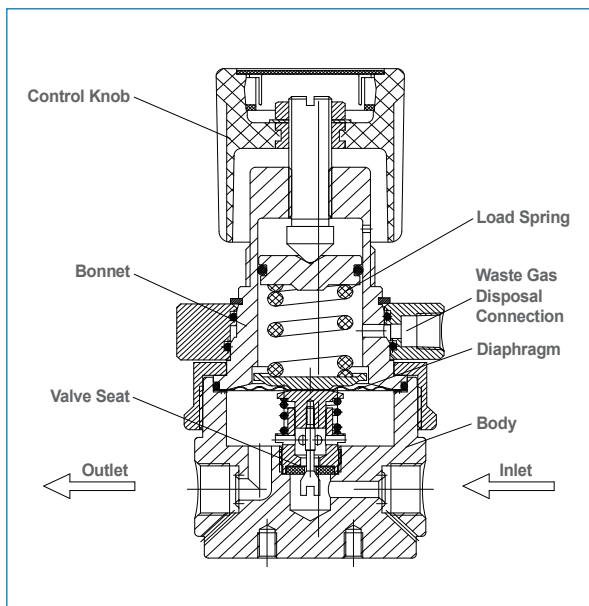

Dimensions

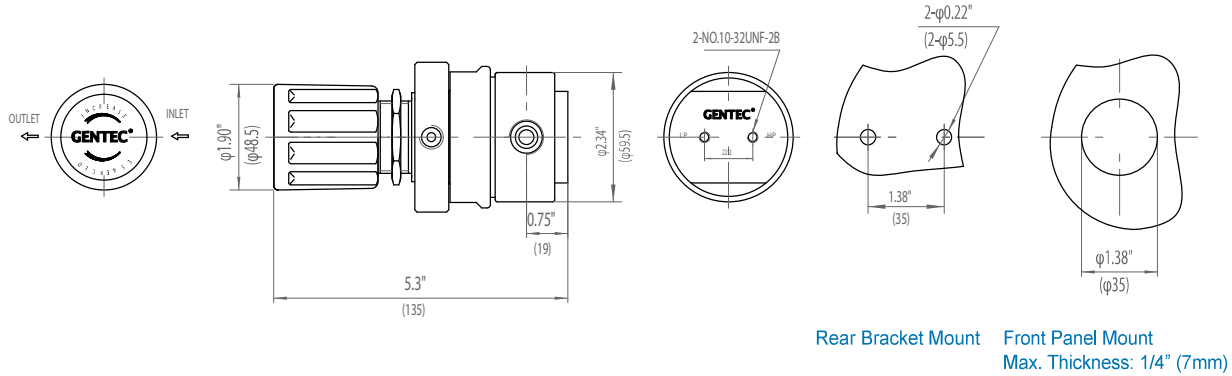

Flow Data

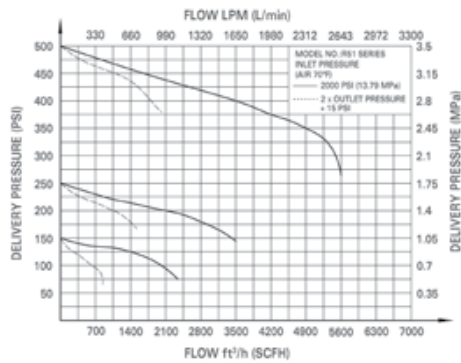

Body Port

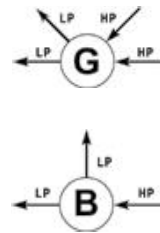

Ordering Information

EX:R51SL	G	K -	D	I	K -	90 -	90
Series	Body Ports	Seat	Inlet Pressure Range	Outlet Pressure Ranges	Gauge	Inlet Connections	Outlet Connections
<ul style="list-style-type: none"> R51SL R51H (Hastelloy®) 	G B	K: PCTFE	D: 3000 psi (206 bar)	G: 0-250 psi (17 bar) H: 0-150 psi (10 bar) I: 0-100 psi (7 bar) K: 0-50 psi (3 bar) L: 0-25 psi (1.5 bar)	P: psi / bar K: psi / kPa W: No Gauge	90: Internal 1/4" FSR(F)	90: Internal 1/4" FSR(F)