

# R53SL SERIES

Tied Diaphragm Regulator

Specialty Gas Equipment



▶ **R51SLGK-DIK-90-90**

## Materials

• Body	316L Stainless Steel
• Bonnet	316L Stainless Steel
• Seat	PCTFE
• Valve Stem:	316L Stainless Steel, Hastelloy®
• Diaphragm	316L Stainless Steel, Hastelloy®

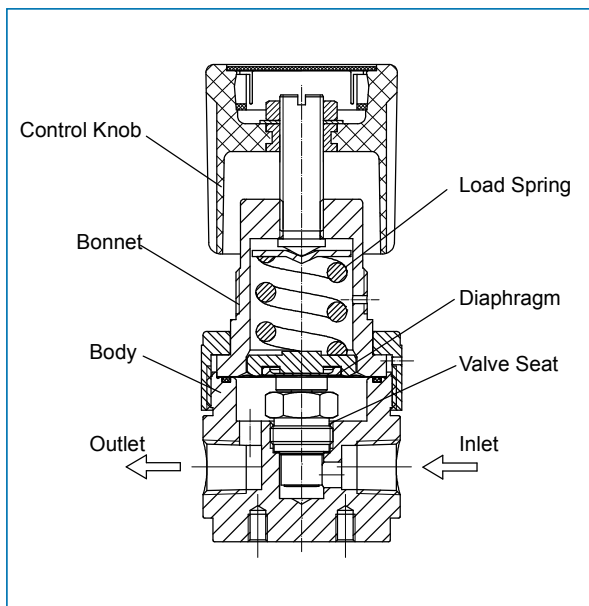

GENTEC® R53SL Series Single Stage Tied Diaphragm Regulator consists of a specially designed link between the diaphragm and main valve. It is designed to prevent “creep” if contaminants should form on the valve seat. This feature improves regulator performance and extends the life of the diaphragm. Additionally, a high flow mesh filter is installed before gas enters the seat. It is attached onto the seat. The entire unit can be swapped out during maintenance of the regulator (seat / filter / nozzle).

Debris prior to the seat will be caught by the filter, preventing debris from entering the regulator.

## Product Features

- Single-Stage Configuration
- Metal-to-Metal diaphragm to body seal & dual layer sealing ring
- Integrated waste gas disposal connection for additional safety
- Inlet & Outlet Port Size: 1/4” NPT(F)
- Internal Hastelloy valve trim providing an extra measure of resistance against corrosion (optional)

## Applications

- Semiconductor Industry
- Research Laboratories
- Regulation of Specialty Gases
- Gas Chromatography
- Oil & Gas
- Device Manufacturers

## Specifications

- Maximum inlet pressure: 3000 psig
- Maximum outlet pressure: 250 psig
- Safety test pressure: 1.5 x Maximum inlet pressure
- Temperature range: -40°F~165°F (-40°C~ 74°C)
- Inboard leakage:  $2 \times 10^{-8}$  atm.cc/sec He
- Outboard leakage:  $2 \times 10^{-8}$  atm.cc/sec He inlet pressure: 1500 psig
- Maximum Cv: 0.14
- Weight: 2.43 lb

**Dimensions**

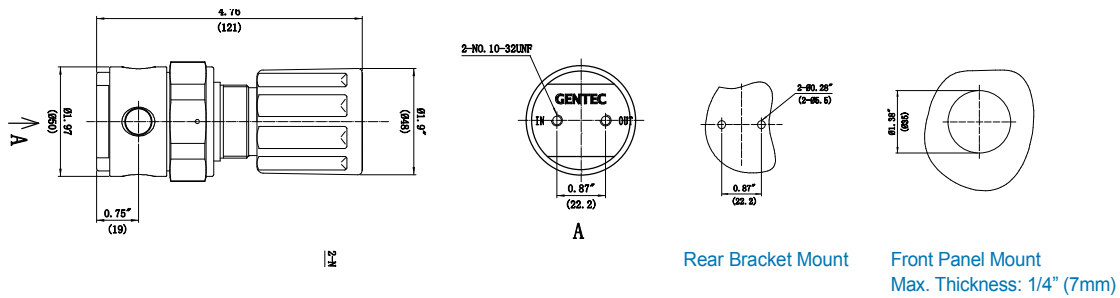

**Flow Data**

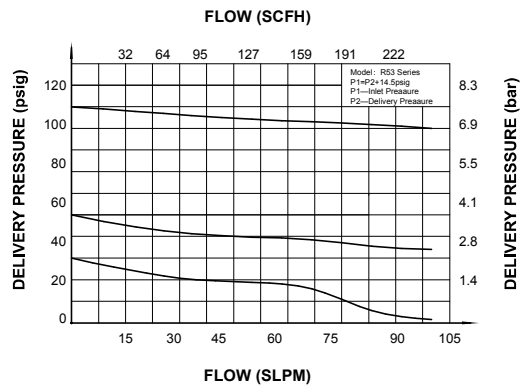
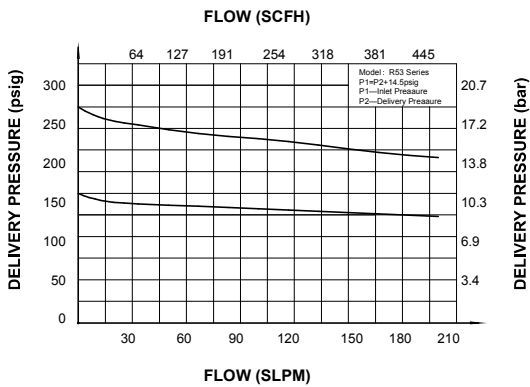

**Ordering Information**

EX:R53SL	Q	K -	D	K	P -	00 -	00 -	H
Series	Body Ports	Seat	Inlet Pressure Range	Outlet Pressure Ranges	Gauge	Inlet Connections	Outlet Connections	Options
• R53SL	A B D G J M Q	K: PCTFE	D: 3000 psig E: 1500 psig F: 500 psig	G: 0~250 psig I: 0~100 psig K: 0~50 psig L: 0~25 psig Q: 30" Hg Vac~30 psig S: 30" Hg Vac~100 psig T: 30" Hg Vac~200 psig	K: psig/kPa P: psig/bar W: No Gauge	00: 1/4" NPT (F) C330: CGA330 C350: CGA350 C580: CGA580 C660: CGA660 C590: CGA590 52: G5/8"-RH (F) 63: W21.8-14RH (F) 64: W21.8-14LH (F) Other connections available	00: 1/4" NPT (F) 10: 1/8" GENLOK 11: 1/4" GENLOK 15: 6 mm GENLOK 16: 8 mm GENLOK 74: M8 x 1RH (M) Other connections available	D: Diaphragm Valve N: Needle Valve R: Relief Valve H: Hastelloy® Valve Stem and Diaphragm