

# DV54 SERIES

Stainless Steel High Purity Diaphragm Valves

GENTEC® Valves



Manual  
(Low Pressure)



Manual  
(High Pressure)

## Surface Finish

- Standard Ra: 10-15  $\mu\text{m}$

## Internal Volume

- 1.6 cc

## Product Features

- Suitable for high purity applications
- 316L stainless steel enhances weldability and resistance to corrosion
- Both manual and pneumatic actuation are available
- Face seal fittings (FSR) or butt welded connections
- Internal spring-less design
- Metal-to-metal seal minimizes particle generation and ensures high purity in the flow passages
- Handle includes a status window to indicate open / closed position
- Long service life
- 100% Helium leak tested

## Materials

- Body: 316L
- Seat: PCTFE\*, Vespel®\*\*
- Diaphragm: Elgiloy®

## Specifications

- Cv: 0.3
- Leak Rate  
Inboard:  $1 \times 10^{-9}$  atm cc/sec He  
Across Seat:  $4 \times 10^{-9}$  atm cc/sec He
- Proof Pressure: 150% of maximum operating pressure
- Burst Pressure: 400% of maximum operating pressure

## Operating Conditions

- Maximum operating pressure: 300 psi (20 bar),  
3500 psi (240 bar)
- Minimum operating pressure: Vacuum
- Operating temperature: 40°F ~ 150°F (-40°C ~ 65°C)

## Pneumatic Actuator

- Operating pressure: 70-125 psi
- Inlet Connection: 1/8" NPT(F)
- Working Status: Normally closed

\* Standard Material

\*\* Vespel® seat is recommended for Nitrous Oxide (N2O) service but is not available for low pressure pneumatic actuation

Dimensions

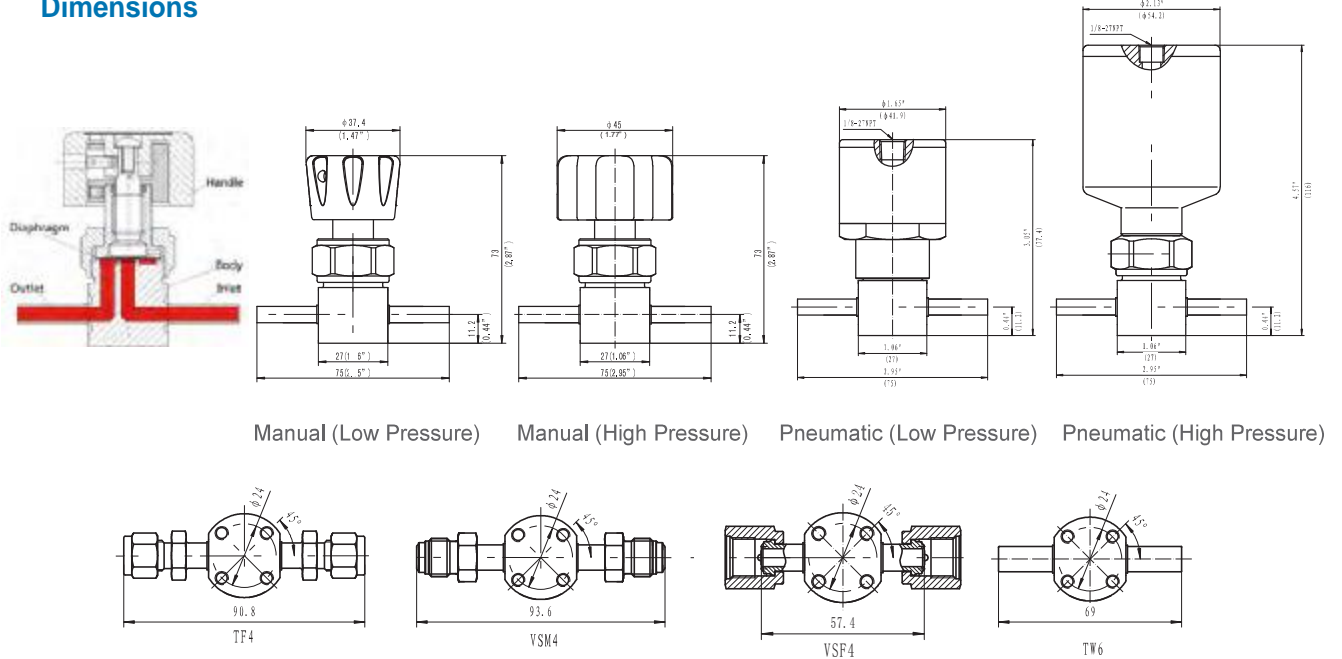

Flow Path Designator

Type	Elbow	Three-way			Four-way		Rear-entry	
Flow schematic	P	B	C	D	I	J	A	T
Red arrow indicates inlet, Blue arrow indicates outlet*								
Flow schematic	Q	E	F	H	K	L	R	
Red arrow indicates inlet, Blue arrow indicates outlet*								

\*All schematics are from top view

Ordering Information

EX: SL - DV54 M H B - TW4 - NO	Body Material	Series	Actuation	Working Pressure	Flow Path	Inlet / Outlet Connection	Options
SL: 136L	DV54	M: Handwheel (with status window) P: Pneumatic actuator (Normally closed)	H: 3500 psi L: 300 psi	Blank: In-line Type Elbow Type P: Right in / top out Q: Right in / bottom out Three-way Valve B: Right inlet, left / top outlet C: Right inlet, left / bottom outlet D: Right / top inlet, left outlet E: Right inlet, top / bottom outlet F: Top / bottom inlet, left outlet H: Left / right inlet, top outlet	Four-way Valve I: Two inlet / two outlet J: One inlet / three outlet K: Two inlet / two outlet (elbow) L: Three inlet / one outlet Rear-entry Valve A: Rear inlet / one outlet T: Rear inlet / two outlet R: Rear inlet / four outlet	TW4 TW6 VSM4 VSF4 TF4	Blank: Standard NO: Normally open (Pneumatic, Low Pressure)

\*: For standard models, if the high pressure (inlet) connections and low pressure (outlet) connections are same, list only one. If different, the prior represents inlet connection, and the latter represents outlet connection.